

# Posters

# **Rethinking of Wooden Heritage- An Overview**

**Sankara Rao<sup>1</sup>**

The use of wood may be traced to the pre-historic period. It was used in different forms like making fire, fuel, boxes, tools, toys, domestic articles, building materials of habitats, pillars, doors, gateways transportation, ritualistic symbols, marriage, palanquins, musical instruments, oil expellers etc. Since the ancient past to the present day, wood and wooden craft have been in continuous promulgation in human society. Indian craftsmen have used wood as one of the important mediums of art expression from the very beginning, mainly because of its availability and ease of use. We still use age old wooden objects and other things in our households because of their long standing use. They are traditional and have been passed on from one generation to the next, and the wisdom, wealth and variety of these works of art and craft is one of the most important cultural inheritances of mankind. The wooden material culture, knowledge and technology of our tribal and rural artisans and craftsmen has a rich heritage in this very old craft of wood carving that reflects the artistic skills on objects of design, function, utility, aesthetics, style and composition of wood and wooden art is highly appreciated in the present society. Wood craft is widely prevalent all over India, but with much regional, provincial and local variety.

The present paper is aimed to discuss various wood and wooden material culture objects of the Indira Gandhi Rashtriya Manav Sangrahalaya (National Museum of Mankind), Bhopal in Central India, Madhya Pradesh, which is one of the largest ethnographic museums in India. The museum is intended to represent, promote and preserve the material culture of different states across the country and also dealt with large scale wooden objects for documentation, display in different exhibitions, research and reference. It also focuses on the social, economic, cultural and environmental importance of wood. It also puts emphasis on how aspects of culture can facilitate creativity, imagination and divergent thinking of wooden art and crafts and how this can be affectively utilized as a learning process a joyful experience.

---

<sup>1</sup> Indira Gandhi Rashtriya Manav Sangrahalaya, (National Museum of Mankind), Post Bag No. 2, Shamlu Hills, 462 013, Madhya Pradesh, INDIA (drpsrao2010@gmail.com)

# Biofuel From woody (Lignocellulosic) Biomass for a Sustainable Future

Vindhya P Tewari<sup>2</sup>

## Abstract

*Using crops to make liquid fuel is not a recent idea. Biofuels are not only preferable to petrol but that there is also hope for biofuels' environmental and social redemption. The International Energy Agency (IEA) has laid out a 'roadmap' to ramp-up the use of biofuels from around 2% of global transport fuel today to 27% by the year 2050. Each year, more than 40 million tonnes of inedible plant material, including wheat stems, corn stover and wood shavings from logging, are produced. Turning these discarded, woody bits of plants into 'second-generation' biofuels has huge appeal. Two important methods are involved in taping this second generation biofuel from lignocellulosic wastes i.e. Biochemical and Thermochemical. Among these, Thermochemical methods coupled with FT Reaction pays the way to liquid fuel which can readily useful by present spark engine.*

*Fast-growing species can be grown on polluted soil, which also helps to reduce soil contamination. These trees convert carbon dioxide into biomass more rapidly than most other plants. Advanced biofuels hold promise of an escape from their predecessors' food-versus-fuel conundrum. Biofuels have been hailed as key to reducing our fossil-fuel dependence. Avoidance of energy crops vying with food crops for land use requires careful selection of species. Second-generation biofuels have their own drawbacks. Large-scale, second-generation biofuel production may take five to ten years. The inedible parts of plants feed the next generation of biofuels. But extracting the energy-containing molecules is a challenging task.*

**Keywords:** Woody biomass, lignocellulose, fermentation, digestion, liquefaction, pyrolysis, gasification, second generation biofuel

---

<sup>2</sup> Institute of Wood Science & Technology, Bangalore, INDIA (vptewari@icfre.org)

## 1. INTRODUCTION

Energy from biomass accounts for 15 percent of energy consumed worldwide and up to 90 percent in some developing countries (FAO, 2004a). Wood energy accounts for 7 to 9 percent of energy consumed worldwide, and up to 80 percent in some developing countries (97 percent in Bhutan, 93 percent in Burundi, 92 percent in Nepal, 80 percent in Paraguay). Woodfuels account for 60 percent of global forest product consumption (FAO, 2004b). Forest biomass is one of the resource available plenty in the nature. 600 million tons of agricultural residues and 25 million tons forest residues are produced annually in India. More than 2 billion people are dependent on woodfuel for cooking, heating and food preservation and several million people are involved in the production, distribution and sale of fuelwood and charcoal (UNDP, 2000). Indian contribution in World Woodfuel production is 17%.

Using crops to make liquid fuel is not a recent idea. As far back as the nineteenth century, Rudolf Diesel designed his eponymous engine to run on vegetable oil or peanut oil. And Brazil has mandated the addition of sugar-cane-derived ethanol to its fuel since 1929 (Graham-Rowe, 2011).

The most controversial aspect of biofuels is the perceived competition for farmland. The advances in biofuels and agriculture may send this trade-off speeding towards the history books.

Biofuels are not only preferable to petrol (gasoline) but, with technological advances, there is also hope for biofuels' environmental and social redemption. Annual output of bioethanol and biodiesel had exploded from 16 million litres worldwide in 2000 to more than 100 million litres in 2010.

The International Energy Agency (IEA) has laid out a 'roadmap' to ramp-up the use of biofuels from around 2% of global transport fuel today to 27% by the year 2050. Biofuels, according to the IEA, could displace enough petroleum to avoid the equivalent of 2.1 gigatonnes of carbon dioxide emission each year if produced sustainably — about as much as net carbon dioxide absorbed by the oceans (Fairley, 2011).

In May 2011, the Intergovernmental Panel on Climate Change (IPCC) issued a report on renewable energy projects concluding that biomass can by mid-century sustainably provide up to 300 exajoules — more than four times the biomass needed to meet the IEA target of 27% of the worlds' transportation fuel coming from biofuels.

## 2. BIOFUEL FROM WOODY BIOMASS

Each year, more than 40 million tonnes of inedible plant material, including wheat stems, corn stover and wood shavings from logging, are produced. Turning these discarded, woody bits of plants into 'second-generation' biofuels has huge appeal (Sanderson, 2011).

The woody material that gives plants their rigidity and structure comprises three main types of carbon-based polymer — cellulose (35-50%), hemicelluloses (25-30%), and

lignin (15-30%) — collectively called lignocellulosic biomass and tightly bonded by physical and chemical interactions. When taken apart, these polymers yield chemical components that can be used to make biofuels.

At present, the best way to break apart these lignocellulosic materials and extract their chemicals for fuel production involves heat and strong chemicals. Conversion of lignocelluloses biomass is more complex due to presence of polysaccharide molecule and hence requires further enzymatic treatment to produce ethanol from sugar.

For now, enzymatic biofuel remains at pilot scale. The enzymes so far discovered are not very efficient, to employ these techniques on a large scale is unsustainable — the existing process consumes more energy than is contained in the molecules it releases (Sanderson, 2011).

The good news is that there are alternative sources of enzymes. Some creatures happily survive on a diet of wood. So perhaps humans just need to find out how these enzymatic processes work and then apply them in an industrial setting.

Cellulose is the best source for glucose because it is highly available, renewable, and does not compete with the food supply. However, this raw material is not soluble in conventional solvents and very resistant to chemical and biological transformations. Although optimistic and pessimistic hypotheses around the transformation of cellulose over solid catalysts can be formulated, regarding the knowledge accumulated on the hydrolysis of cellulose over the last century, current practice has demonstrated that there is indeed promise (Rinaldi and Schuth, 2009).

Advanced biofuels hold promise of an escape from their predecessors' food-versus-fuel conundrum (Graham-Rowe, 2011). The problem is their presently higher production cost compared with first-generation biofuels and petroleum fuels. At the moment, advanced biofuels are far from competitive — but that should change. The IEA estimates that by 2050, cellulose-based biofuels will be produced for as little as 75 US cents per litre-equivalent. But bridging the gap will require continued investment, research and development. But the ground is shifting back towards bio-fuels, partly owing to a series of natural disasters and societal shifts that have heightened the urgency of avoiding petroleum.

Biomass can be converted into useful forms of energy using a number of different processes. Conversion of biomass energy is undertaken using two main process technologies, Bio-chemical/Biological and Thermochemical, for producing energy from biomass. Factors that influence the choice of conversion process are:

- Type and quantity of biomass feedstock.
- Desired form of the Energy
- Environmental standards
- Economic conditions.

### **3. BIOCHEMICAL CONVERSION**

Biochemical conversion encompasses two process options:

- Fermentation (Production of ethanol)
- Digestion (Production of biogas, a mixture of mainly methane & CO<sub>2</sub>)

#### **3.1 Fermentation**

Fermentation is used commercially on a large-scale in many countries to produce ethanol from sugar crops (e.g. sugarcane, sugar beet) and starch crops (e.g. maize, wheat). The biomass is ground down and the starch is converted by enzymes to sugars, with yeast then converting the sugars to ethanol. But the conversion of lignocellulosic biomass (such as wood and grasses) is more complex, due to the presence of longer-chain polysaccharide molecules and requires acid or enzymatic hydrolysis before the resulting sugars can be fermented to ethanol. Such hydrolysis techniques are currently at the pilot stage. While conventional processes for ethanol production use only the biomass components like sugar and starch, R&D focuses on advanced processes that utilize all available lignocellulose materials like cellulose waste, cereal straw and food processing waste (McKendry, 2002). India is one of the largest producers of ethanol and currently all commercial ethanol production in country uses molasses as feedstock. However, most of it is consumed for application in liquor and chemical industries and surplus availability can barely support the demand created by mandatory 5% blending of ethanol in gasoline implemented several states (Sukumaran et al., 2010).

#### **3.2 Anaerobic digestion**

Anaerobic digestion is the conversion of organic material directly to a gas, termed biogas, a mixture of mainly methane and carbon dioxide with small quantities of other gases such as hydrogen sulphide (EU, 1999). The biomass is converted by bacteria in an anaerobic environment, producing a gas with an energy content of about 20–40% of the lower heating value of the feedstock. Anaerobic digestion is a commercially proven technology and is widely used for treating high moisture content organic wastes. Biogas can be used directly in spark ignition gas engine and gas turbines and also it can be upgraded to higher quality i.e. natural gas quality, by the removal of CO<sub>2</sub> (McKendry, 2002).

#### **3.3 Limitations of biochemical conversion**

Biochemical routes, however, face some challenges such as:

- High pre-treatment
- Enzyme costs
- Low fermentability of mixed sugar stream
- Generation of inhibitory soluble compound (e.g. acetic acid, furfural etc.)
- Biochemical routes produce only ethanol
- In biochemical process, especially fermentation process, ethanol is produced from crops like sugarcane, wheat etc. but in a country like India with the

worlds second largest population to feed, sparing food crops for ethanol production is not an option

#### 4. THERMOCHEMICAL CONVERSION

Thermochemical conversion provides following four options:

- Combustion
- Pyrolysis
- Gasification
- Liquefaction

##### 4.1 Combustion

The burning of biomass in air is called combustion. This process can be used over a wide range of outputs to convert the chemical energy stored in biomass into heat, mechanical power or electricity using various items of process equipment. Combustion of biomass produces hot gases at temperatures around 800–10000C. It is possible to burn any type of biomass but in practice combustion is feasible only for biomass with a moisture content <50%, unless the biomass is pre-dried. Net bio-energy conversion efficiencies for biomass combustion power plants range from 20% to 40% (McKendry, 2002). In India, till March 2005, power generation capacity of about 302 MW was commissioned through 54 projects (MNES, 2005). A further capacity addition of about 270 MW through 39 projects was reported to be under implementation.

##### 4.2 Pyrolysis

Pyrolysis is the conversion of biomass to liquid, solid and gaseous fractions, by heating the biomass in the absence of air to around 500<sup>0</sup>C. The conversion of biomass to bio-crude with an efficiency of up to 80% (Anon, 1993; EU, 1999; Anon, 1996) has been achieved. Problems with the conversion process and subsequent use of the oil, such as its poor thermal stability and its corrosivity, still need to be overcome.



##### 4.3 Liquefaction

Thermochemical liquefaction is conversion of biomass in to a stable liquid hydrocarbon using low temperature and hydrogen pressure. The interest in liquefaction is low because the reactors and fuel feeding system are more complex and more expensive than pyrolysis process.

##### 4.4 Gasification

Gasification is the conversion of biomass into a combustible gas mixture by the partial oxidation of biomass at high temperatures, typically in the range 800–900<sup>0</sup>C.

Biomass gasification results in production of combustible gases consisting of Carbon monoxide (CO), Hydrogen (H<sub>2</sub>) and traces of Methane (CH<sub>4</sub>). This mixture is called the Producer Gas. The gas produced can be burnt directly or used as a fuel for gas engines and gas turbines to convert the gaseous fuel to electricity with high overall conversion efficiency or it can be made into liquid form in the presence of Catalysts (Ni, Fe, Co), in high pressure and heat. The gasification ensures high conversion efficiency, producing net efficiencies of 70–80%. In India, at present, there are 1900 gasifier running successfully by support of Ministry of Non-conventional Energy Sources (MNES) having power production of 100 MW (MNES, 2008).

Gasification coupled with catalytic conversion to liquid using Fischer-Tropsch (FT) process, Biomass to Liquid Technology (BTL), proved to be an efficient technology for biofuel production. FT synthesis can be characterized by unavoidable production of wide range of hydrocarbon products (olefins, paraffin and oxygenated products). FT synthesis is in principle a carbon chain building process where CH<sub>2</sub> groups are attached to the carbon chain. The reaction is dependent of catalyst mostly an iron or cobalt catalyst, Ruthenium (Ru) can also be used as catalyst but its availability is low. In FT coupled gasification, the synthesis gas produced by gasification may be fed into FT reactor where the chain growth takes place thus producing a wide range of hydrocarbons like gasoline and bio diesel. The largest Coal to Liquid (CTL) producer is Germany (IEA, 2007).

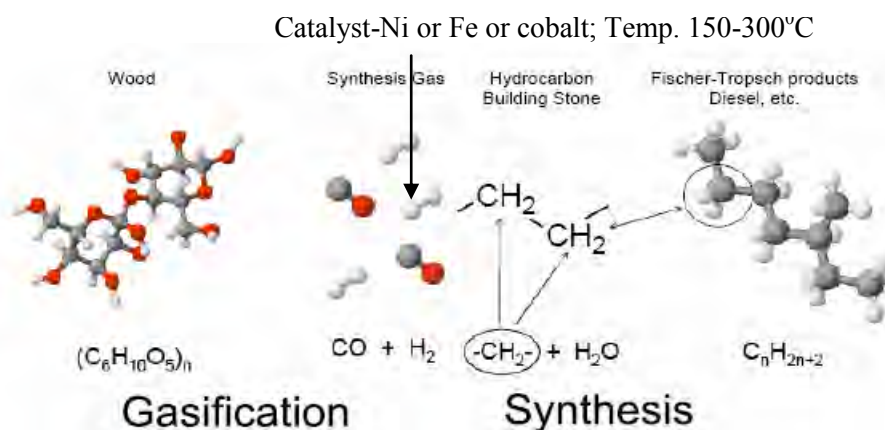

Biomass to Liquid (BTL) has many advantages (NTNU, 2005) such as:

- Fits to any diesel engine / current infrastructure system
- Sustainable / renewable and almost CO<sub>2</sub> neutral
- Clean fuel – no SO<sub>x</sub>, high reduction in NO<sub>x</sub> and particle emissions
- Significantly higher yield per acre than 1st generation bio-fuel.
- High energy density (~ 40 MJ per Liter)
- Highly stable – storage & transport not an issue
- Produced domestically – creates jobs
- Broadest feedstock base of any biofuel
- Energy security



#### 4.5 Merits of thermochemical conversion (specially Gasification) (Sims *et al.*, 2010)

- Thermochemical routes can be employed to produce a range of longer chain hydrocarbon from synthesis gas.
- The synthesis gas can also be converted to methanol as well as to higher alcohols for transport fuel application using modified catalyst to provide better yield.
- Although combustion and Pyrolysis have been considered as one of the processes for biomass energy conversion but conversion of biomass by gasification into fuel suitable for use in gas engine increases greatly the potential usefulness of biomass as renewable resources.
- Gasification is a robust proven technology that can be operated either as a simple low technology system based on a fixed bed gasifier.
- Unlike combustion, where oxidation is substantially complete in one process, gasification converts intrinsic chemical energy of the carbon in biomass into a combustible gas in two stages.
- The gas produced can be standardised in its quality and can be used to power gas engines and gas turbines or used as a chemical feedstock to produce liquid fuels.

### 5. SUGGESTIONS AND REMARKS

To avoid the energy crops vying with food crops for land use requires careful selection of species. Fast-growing species of willow or poplar trees, for example, can be grown on polluted soil, which also helps to reduce soil contamination (Graham-Rowe, 2011). These trees convert carbon dioxide into biomass more rapidly than most other plants — a trait that should translate into high biomass yields.

Progress in biofuels requires not just technical advances, but a level of predictability in the economic and policy terrain. The problem is a lack of consensus on how to measure environmental impacts of biofuels.

Biofuels have been hailed as key to reducing our fossil-fuel dependence, yet their environmental and social impacts remain uncertain (Robins, 2011). A biomass-based fuel needs to be cheap and energy dense (Savage, 2011). With BTL process, lignocellulose biomass can efficiently be used to produce biofuel which can directly be used in spark ignition gas engine.

Second-generation biofuels have their own drawbacks. They still require land, and even plants that need minimal input will compete with food crops for some resources (Graham-Rowe, 2011). Large-scale, second-generation biofuel production may take five to ten years. The inedible parts of plants are feeding the next generation of biofuels. But extracting the energy-containing molecules is a challenging task.

The biggest hurdle faced by these second-generation biofuel technologies is not a dearth of clever science. It is the lack of brave investors willing to take a gamble on a new technology and the absence of enforced legislation that would encourage the production of cellulosic biofuels over first generation crop-based fuels (Sanderson,

2011). Until these problems are solved, woody plants will be able to cling tight to their stash of fuel for a little longer.

## 6. REFERENCES

Anon, 1993. An assessment of Thermochemical Conversion systems for processing Biomass and Wastes. Aston University and DK Teknik, ETSU, B/T1/00207/Rep.

Anon, 1996. The Fast Pyrolysis of Oilseed Rape. Aston University, ETSU, B/M5/00533/18/Rep.

EU, 1999. Biomass Conversion Technologies. European Union, EUR 18029 EN ISBN 92-828-5368-3.

FAO, 2004a. Interactive Wood Energy Statistics. Wood Energy Programme. Forest Products and Economic Division. FAO, Rome.

FAO, 2004b. FAOSTAT. FAO, Rome

Fairley, P, 2011. Next Generation Biofuel. *Nature*, 474(22), 2-5.

Graham-Rowe, D, 2011. Beyond Food versus Fuel. *Nature*, 474(22), 6-8.

IEA, 2007. Biofuel Production. International Energy Agency (IEA) Energy Technology Essentials.

McKendry, P, 2002. Energy production from Biomass (Part 2): Conversion technologies. *Bioresources Technology*, 83(1), 47-54.

MNES, 2005. Ministry of Non-Conventional Energy Sources, GOI. Booklet Series-2 Biomass.

MNES, 2008. Annual Report, Ministry of Non-Conventional Energy Sources, Govt. of India.

NTNU, 2005. Biofuels from lignocellulosic material-in the Norwegian context 2010-Technology, Potential and Costs. Faculty of Information Technology, Mathematics and Electrical Engineering, Department of Electrical Engineering, Norwegian University of Science and Technology.

Rinaldi, R and Schuth, F, 2009. Acid Hydrolysis of Cellulose as the Entry Point into Biorefinery Schemes. *ChemSusChem*, 2, 1096-1107.

Robins, M, 2011. Fuelling Politics. *Nature*, 474(22), 22-24.

Sanderson, K, 2011. Lignocellulose: A Chewy Problem. *Nature*, 474(22), 12-15.

Savage, N, 2011. The Ideal Biofuel. *Nature*, 474(22), 9-11.

Sims, REH, Mabee, W, Saddler, JN, Taylor, M, 2010. An Overview of Second Generation Biofuel technologies. *Bioresource Technology*, 101, 1570-1580.

Sukumaran, RK, Surender, VJ, Sindhu, R, Binod, P, Janu, KU, Sajna, KV, Rajasree, KP and Pandey, A, 2010. Lignocellulosic ethanol in India: Prospects, Challenges and Feedstock availability. *Bioresource Technology*, 101(13), 4826-4833.

UNDP, 2000. UNDP, UNDESA and World Energy Council. *World Energy Assessment*, UNDP, New York.

# Heritage Wood Craft: Perspective on Decay Management

H C Nagaveni<sup>3</sup>

## Abstract

*The tradition of wood-carving has existed in India and other countries from ancient times. The early wood-carved temples bear witness to the craft. Wood-carved temples and chariots still exist in different places in India and each region has developed its own style of carving influenced by local traditions and wood varieties. Most places of worship include large carvings of mythical figures like half-man, Garuda, Hanuman and lion etc. Folk forms in woodwork include toys, puppets and religious objects and carvings. Wooden cultural properties are degraded by microorganisms when moisture, oxygen and other environmental factors are favorable for microbial growth resulting in disfigurement and spoiling the beauty of carvings by change of color and shape. Fungi produce large numbers of spores and when these spores liberated from infected heritage buildings/ carvings to the indoor air, it can be regarded as organic dust. These spores can, like other types of dust, result in sediment on surfaces or it could be inhaled by occupants and deposited on the mucosal surface of the upper airways and in the eyes. Repeated exposure to large amount of fungal propagule risks the development of specific allergic reactions.*

*Management of these sculptures in good condition by controlling the environment around a susceptible biodegradable material is still the most frequently used method of preventing biological decay. Correct identification of the fungal material is important, as not all fungi are equally destructive. Some rots are present in timber when it is cut or are acquired during storage. Management of decay and health problems in heritage buildings and wood craft is a complex issue and requires a multidisciplinary integrated approach, which combines the skills of pathologist & architects and with environment monitoring. One can enjoy the traditional wood craft following proper management strategies. Details of the decay problem and their management are dealt in the present paper.*

**Key words:** Wood-artifact, decay fungi, and culture-heritage

---

<sup>3</sup> Institute of Wood Science & Technology, Malleswaram, Bangalore-560003, INDIA  
(hcnagaveni@icfre.org)

## 1. INTRODUCTION

The custom of wood-art has existed in India and also in many countries from primeval times. In India, each region has developed its own style of carving influenced by local traditions and wood varieties. Folk forms in woodwork include toys, puppets and religious objects and carvings. In many places in India, wood-carvers work wonders.

In south Kanara (Karnataka), life-size wood carving of Buddha figures are common. Mysore has an intricate form of ivory-inlay on wood that can be seen on the ceilings and doors of the Mysore Palace. In Orissa, the main deity of the famed Puri temple, Lord Jagannath, is reproduced in wood. Nagaland has a tradition of manufacturing statues as well as commemorative pillars in wood. Most places of worship include large carvings of mythical figures like half-man, Garuda, Hanuman and lion. In West Bengal, clay houses have large wooden pillars and beams with intricate carvings. In Kashmir, houses are lined with wood, with ceilings in geometrical patterns and lattice-worked windows made up of pieces of wood. The state also produces items like decorative wood panels on ceilings, furniture, screens, boxes and bowls, mostly prepared from walnut wood, which is found in abundance. Ahmedabad in Gujarat is a witness to some of the finest ornamental carvings of balconies in old homes. Bedposts and cradles and toys for children are also made here. The Tanjore dolls of Tamil Nadu made of wood form a part of the rituals in temples that also have carved wooden pillars. In Andhra Pradesh, Tirupathi's red dolls are sold at the temple complex. Kerala has one of the richest traditions in woodcarving. Old homes have carved doors and windows.

Different durable species are used for this wood-art. Wood indoors or exposed to outdoors conditions can last for centuries without any decay problems provided the wood is not exposed to moisture or any other hazardous conditions. Historic and archaeological woods are important cultural objects that provide valuable information about the past. Wood in the environment, however, is deteriorated by a wide variety of biotic and abiotic processes. Usually, wood that survives long periods of time is recovered from environments that limit degradation. Even in some of the most extreme terrestrial sites, such as in desert or polar ecosystems, the adverse and restrictive environment allows wood deterioration to occur. Wooden works are degraded by microorganisms when moisture, oxygen and other environmental factors are favorable for microbial growth resulting in disfigurement and spoiling the beauty of carvings by change of color and shape. Although deterioration may take place slowly, substantial degradation can occur over time. Recent findings have indicated that salts and other non-biological agents can have a significant impact on the integrity of historic and archaeological woods (Blanchette et al. 2002 ) and biological decay by soft rot fungi can be common (Blanchette et al. 2004). Weathering and decay are the main cause which influences the service life of wood and wood-art. Weathering of wood in turn leads to decay problems. Tackling these two problems and managing them is a very important aspect to maintain the heritage of wood-art in good condition.

### **Decay problems in Wood-art**

Wood deteriorates rapidly from a variety of different biotic processes when exposed to different environmental conditions. When moisture, oxygen and other

environmental factors are favorable, fungus will grow and devastate the appearance of the art-work. Archaeological woods recovered from most environments suffer from some form of bio-deterioration. Wood destroying fungi cause extensive losses to wood products throughout the world. Historic and archaeological woods that survive long periods of time are usually found in environments that limit decomposition. However, these woods are rarely found free of microbial attack. The wood destroying fungi associated with decay in archaeological wood are seldom identified and little is known about these organisms (Blanchette, 1991). 'Huts in the Ross Sea Region' of Antarctica built by Robert F. Scott and Ernest Shackleton (1902 – 1911), 'Canadian High Arctic' erected during the Franklin era (1852) were studied by the U.S. expeditions. These investigations were done to better understand decomposition processes occurring in Polar Regions and to develop conservation efforts to preserve these important international historic sites. Additional investigations were also done on wood structures located in relatively arid sites built in the southwestern United States by Native North Americans. Decay assessments were done and samples obtained from wooden beams and supports in mud brick great houses erected approximately 1000 years ago in what is currently Chaco Culture National Historic Park and Aztec Ruins National Monument located in New Mexico, USA.

Major agents of wood deterioration causing disfigurement and decay are filamentous fungi. The vegetative or non-reproductive part of the life histories of the filamentous fungi brings about the invasion and colonization of damp wood through the apical growth of hyphae and penetrates the wood by eating different parts of cell wall. The decay process under ideal conditions is a linear continuum that begins with a few innocuous spores and ends when the wood is destroyed or mineralized. When conditions are unfavorable, fruiting bodies (Sporophore) are formed and shed the spores, which alight on damp wood and life cycle continues. The characteristic softening, discoloration and eventual disintegration of wood takes place in decaying process in timbers and also large numbers of spores are liberated from fungi in infected heritage buildings/ carvings to the indoor air, which can be regarded as organic dust. These spores can, like other types of dust, sediment on surfaces or it could be inhaled by occupants and deposited on the mucosal surface of the upper airways and in the eyes leads to the development of specific allergic reactions.

Decay caused by soft rot fungi was the major type of degradation found in woods from the historic sites in Antarctica and the Arctic. Many different *Cadophora* species were found including *C. malorum*, *C. luteo-olivacea* and *C. fastigiata*, as well as several unique species not previously reported. Soft rot fungi were also found affecting the woods from the Native American great houses in 'New Mexico'. Several *Scytalidium* like isolates were found as well as other undescribed Ascomycetes. Historic wood in contact with the ground at these arid sites were also colonized by basidiomycetes including brown rot fungi. Currently, molecular characterization and phylogenetic analyses are providing a more complete understanding of the fungi causing damage to wooden archaeological structures in different environments. Additional information is now needed on the biology and ecology of these unique organisms in order to properly conserve these wooden structures and prevent their continued degradation from wood destroying fungi. Soft rot fungi appear to be very prevalent in extreme environments that restrict the growth of white and brown rot fungi (Blanchette, 2000). Visually, soft rot may resemble other forms of decay but microscopically the decay patterns produced are distinct. They consist of two forms of

degradation: type 1 and type 2. Soft rot fungi that cause type 1 attack grow into the lumina of wood cells and penetrate the secondary cell wall (Daniel and Nilsson 1998, Eaton and Hale 1993). As the hyphae grow in the wall, degradative enzymes are produced and cavities inside the wall are formed. Chains of conical-shaped cavities follow the microfibrillar structure of the cell wall producing a spiral of elongate holes inside the secondary wall. Type 2 attack is characterized by an erosion of the secondary wall as the hyphae grow in the cell lumina (Eriksson et al,1990, Daniel and Nilsson,1998). The wall is progressively eroded from the cell lumen toward the middle lamella and in advanced stages of degradation the entire secondary wall may be removed. The middle lamella, however, is not degraded. Several studies have investigated the various types of decay that have occurred in historic and archaeological woods (Blanchette, 2000, Blanchette et al., 1994). Active wood destroyer *Serpula lacrymans*, under appropriate conditions are able to destroy buildings in several years. Characterization of the decay is important since it provides information on the type of attack that has taken place, the extent of degradation and current condition of the wood. Few studies, however, have been done to identify the microorganisms involved in the decay processes taking place in historic and archaeological wood. Russian wooden architectural monument- St. Nicholas church ensemble in the village of Kovda in Murmansk region at the shore of Kandalaksha Bay of the White Sea (Stephen J Kelley, 1954) are destroyed due to *S. lacrymans*.

Outdoor wood-art faces the problem of photo-degradation, where lignin and cellulose are degraded by forming free radicals and this process is accelerated by the presence of oxygen and moisture along with bio-degradation with fungal invasion. Protection is very important to guard the heritage wood art from damage. The type of protection to be adopted may vary with type of art work and whether it is kept indoor or outdoor and the type of environment etc.

### **Restoration strategy and protection of wood-art**

The rate of wood decay is an important factor to bear in mind when choosing a restoration strategy for wooden architectural monuments/artifacts. Carrying out restoration hurriedly often leads to the destruction of authentic monuments because of restoration strategy fails to take into account the natural conservation of the wood caused by the biological equilibrium between wood decomposing organisms established during the period of a monuments life. This equilibrium results in minimizing of dangerous fungi activity and prevents the active growth and spread of the dangerous building rot fungi. As for old buildings that have been in existence for centuries, contamination by the fungi also happened long ago. This monument represents an example of natural wood conservation as well as an appropriate restoration that has lead to the destruction of this unique monument.

Many factors influence the microbial invasion, colonization and consequent deterioration of wood. These include the nature of the substrate itself (wood), the situation in which wood is exposed, the environmental conditions in that situation and the presence or not of any preservative treatment in the wood. Moisture content of timber is usually most critical factor in the establishment and continuation of decay of timber in heritage buildings/wood sculptures, and it may have an influence on the type of decay that develops. The moisture content of timber is related to the humidity or dampness of its environment. Conversely, in buildings which are correctly designed,

constructed and maintained and well-aerated where the wood artifact will not absorb moisture, the wood will be free from fungal attack. When wood is too dry (below 20%), the decay will be arrested. When, wooden monuments/artifact cannot be kept dry and constantly exposed to humid condition, treatment with wood preservatives is necessary. Wood preservatives contain toxic substances designed to inhibit the activity and viability of organisms.

In situ protection of wood in structure poses a real challenge. Portable/small wood-art objects are easy to handle and can be kept under controlled conditions or may be subjected to treatment or some safety measures can be adopted to prevent decay. A large number of chemicals are available for restoration of damaged objects and their future preservation. The choice and use is however is limited as some of the chemical leaves the stain or alter its natural color. Depending on necessity, chemical preservative and type of treatment may be decided.

There are two commonly available inexpensive materials that will kill rot in wood and prevent its recurrence. First, there are borates (borax-boric acid mixtures) which have an established record in preventing rot in wood and in killing rot organisms and also wood-destroying insects in infested wood. Second, there is ethylene glycol, most readily available as auto antifreeze-coolant. Glycol is toxic to the whole spectrum of organisms from staphylococcus bacteria to mammals. Both borate solutions and glycol penetrate dry and wet wood well because they are water-soluble; in fact, penetration by glycol is especially helped by its extreme hygroscopicity. Glycol penetrates rapidly through all paint, varnish, and oil finishes (except epoxy and polyurethanes) without lifting or damaging those finishes in any way. One can treat all of the wood-art without removing any finish. The dyes in glycol antifreeze are so weak that they do not discolor even white woods. Once bare wood has been treated with glycol or the borate solutions and become dry to the touch it can be finished or glued. If a borate solution leaves white residues on the surface, it will have to be washed off with water and the surface allowed for drying.

Polyethylene glycols and various types of monomers have been used for impregnation of wood to make them dimensionally stable. These bulking treatments can keep the wood fairly dry and protect it from fungal attack (Mitchell, 1972).

Chromic acid treatment on wood surface has been found to enhance resistance to photo-degradation (Feist, 1979) and fungus (Nagaveni et al, 2001). Similar results were reported from 'Ammonical copper-chromate (ACC)' and 'Ammonical copper-chromate arsenate (ACCA)'. Treating the wood surface with resorcinol solution prior to treating with acid-copper-chromate improves the permanence of chemical in wood as well as imparted natural brown color. Other effective coatings for protection against weathering are Cupriethylene diamine, Copper molybdate and Copper ferricyanide.

Pentachlorophenol dissolved in mineral solvents and containing paraffin wax are water repellent preservative (WRP) is an excellent wood preservative for long protection of wood against mold fungus, insects and even water. Water repellents consisting of resins dissolved in mineral spirits with addition of wax have also been found to perform well (Feist and Marz, 1978). Some paints are fungus resistant paint, which may be used for humid area where wood art is kept. Special formulated paints



containing preserving chemicals can protect wood against decay (Hoffmann et al 1973). The basic principle of such protection is to keep the water out. Water repellent preservatives are better for overall protection of wood sculpture.

Outdoor protection of wood needs specially formulated systems, especially in situations where the natural look of the wood surface to be maintained. Application of monomers like Methyl-methacrylate and their in-situ polymerization may restore the degraded surface and protect the wood from future degradation (Fiest and Rowell, 1982).

For complete protection of wood, incorporation of toxic chemicals in the wood is necessary. Since it is not possible to impregnate chemicals without pressure treatment fumigants such as Chloropicrin, Methyl isocyanate and N-methyl-dithio-carbonate) may be encapsulated in gelatin for slow release of the chemical and can be expected to be effective for period of 10- 15 years or even more depending on exposed conditions.

The chemical preservation mentioned should be adopted depending on the situation of the wood art, type of fungal attack and its environmental factor association. If one understands the situation, management strategy can be adopted accordingly and this cultural heritage can remain undisturbed so that future generations can enjoy the beauty of wooden art work.

## 2. REFERENCES

Blanchette, R.A., K.R. Cease, A.R. Abad, R. J. Koastler, E. Simpson & G.K. Sams. 1991. An evaluation of different forms of deterioration found in archaeological wood. *Int. Biodeterioration* 28: 3–22.

robert a. blanchette, john e. haight, robert j. koestler, pamel a. hatchfield, & dorthea arnold 1994. Assessment of deterioration in archaeological wood from ancient Egypt. *JAIC* 33, (5): 55 to 70.

Robert A. Blanchette, Joel A. Jurgens, Benjamin W. Held, Brett E. Arenz and Jason A. Smith. 1991. Decay of historic and archaeological wooden structures: degradation processes and molecular characterization of wood destroying fungi. *International Academy Wood Science*. [iaws-web.org/paperschile.html](http://iaws-web.org/paperschile.html)

Blanchette, R.A. 1995. Biodeterioration of archaeological wood. *Biodeterioration Abstract* 9: 113–127.

Daniel, G.F. & T. Nilsson. 1998. Developments in the study of soft rot and bacterial decay. In: A. Bruce & J.W. Palfreymann (eds.), *Forest products biotechnology*: 37–62. Tayler & Francis Ltd, London.

Eaton, R.A. & M.D.C. Hale. 1993. *Wood: decay, pests and protection*. Chapman & Hall, London.

- Eriksson, K.E.L., R.A. Blanchette & P. Ander. 1990. Microbial and enzymatic degradation of wood and wood components. Springer Verlag, Berlin.
- Feist, W.C. 1979. 'Protection of wood surface with chromium trioxide' USDA forest service, FPL (Madison) Research paper, FPL 339.
- Feist W.C. and Marz, E.A. 1978. Protecting mill work with water repellent. Forest Prod. Journal. 28 (5): 31-35.
- Hoffmann, E., Hill, R.K., and Saracz, A. 1973. Fungus resistant paints for breweries and humid tropics. J. Oil and Color, Chemist Assoc., 56: 17-27.
- Mitchell, H. L., 1972. How P E G helps the hobby is to who works with wood. Forest Products Laboratory, 2 Forest Service U.S. Department of Agriculture, 1972.
- Nagaveni, H.C., H.S. Anathapadmanabha, G. Vijayalakshmi and S.S. Chauhan. 2001. Effect of Chromic acid treatment on fungal Deterioration of Rubber Wood. Wood News. 11:38-39.
- Stephen J Kelley, Joseph R. L., Alexander S and E George stern 1954. Wooden structures- A global forum on the treatment, Conservation and repair of cultural heritage. ASTM special technical publication- 1351.

# Indian's Choice of Timbers as Reflected in Wood Import Through South Indian Seaports

P. Manickam<sup>4</sup> and R. Sundararaj<sup>5</sup>

## Abstract

*The present paper analyses India's choice of timbers as reflected in the woods imported through five south Indian seaports viz., Chennai Port (Tamil Nadu), Cochin Port (Kerala) New Mangalore Port (Karnataka), Tuticorin Port Trust (Tamil Nadu), and Visakhapatnam Port (Andhra Pradesh) during the years 2004-09. The study revealed that these ports imported 120 types of wood species from 62 countries. The total quantity of wood imported was 51.229 Cu. M. lakhs during the period in which the major wood species imported was Teak logs, *Tectona grandis*. (23.528 Cu. M. lakhs) followed by Gurjan logs, *Dipterocarpus sp.* (9.176 Cu. M. lakhs), Pyinkado logs, *Xylia sp.* (6.331 Cu. M. lakhs), Beech logs, *Fagus sp.* (4.982 Cu. M. lakhs), Maple logs, *Acer sp.* (4.246 Cu. M. lakhs), Merbau logs, *Instia sp.* (2.011 Cu. M. lakhs) and remaining woods to the tune of 0.955 Cu. M. lakhs. The analysis indicated teak as the most preferred wood species in India as it forms 45.93% of wood imported and these findings are presented in this communication.*

**Keywords:** India, wood import, *Tectona grandis*

---

<sup>4</sup> Deputy Director, Plant Quarantine Station, Bangalore- 560 017.

<sup>5</sup> Institute of Wood Science & Technology, Malleswaram, Bangalore- 560 003  
(rsundariwst@gmail.com, rsundararaj@icfre.org)

## 1. INTRODUCTION

Wood is one of the most important renewable natural resources available to man. It is perhaps the first material used by man since time memorial when he was roaming the icy wilderness and is prevalent in our everyday lives and in the economy at large (Bell and Rand, 2006). Until this century wood was the single greatest material aid and comfort in every century of our ancestors lives. It is the prime product of forests for diverse industrial and structural applications. Contrary to common but incorrect perceptions, use of wood is in fact ever increasing, more so in developing countries like India (Rao, 2002). On a worldwide scale, the industrial use of wood approximates that of cement and steel and far exceeds plastics (Schulz, 1991). Along with new uses, more and more applications of wood are being re-discovered and documented, especially its importance as an environmentally friendly material that is remarkably reusable, recyclable, biodegradable and more importantly, as a renewable natural resource. Because of the many advantages in its usage, it is put to a myriad of applications. India is a timber deficient country meeting major demands by wood imports and is importing wood and forest products to the tune of approximately US\$1,028 million every year (FAO, 2000). According to International Tropical Timber Council survey, India is emerging as a major importer of tropical timber (Duncan, 2003) with the demand predicted to rise from 60 million Cu. M. in 2005 to 153 million Cu. M. in 2020, and domestic production is likely to meet only 60 million Cu. M. (Lawson and Hemery, 2007). This paper analyses the Indian's choice of timbers as reflected in the woods imported through south Indian seaports viz., Tuticorin Port Trust (Tamil Nadu), New Mangalore Port (Karnataka), Chennai Port (Tamil Nadu), Cochin Port (Kerala) and Visakhapatnam Port (Andhra Pradesh) during the years 2004-09 and the findings are presented.

## 2. MATERIAL AND METHODS

Details of woods imported through five south Indian seaports viz., Chennai Port (Tamil Nadu), Cochin Port (Kerala), New Mangalore Port (Karnataka), Tuticorin Port Trust (Tamil Nadu), and Visakhapatnam Port (Andhra Pradesh) during the years 2004-09 were collected from the concerned Plant Quarantine Stations of south India and Directorate of Plant Protection Quarantine and Storage, Faridabad. Chennai port is the third oldest among the major 12 ports of India and is an emerging hub port in the East Coast of India. It is strategically located and well connected with major parts of the world and is the hub port on the Indian subcontinent. The port of Cochin is located on the south west coast of India, at Willingdon Island in the state of Kerala. It is a natural seaport, which is located strategically close to the busiest international sea routes. Mangalore port is on the West that imports wood required for most parts of Karnataka, Kerala and some parts of Andhra Pradesh, Maharashtra and Tamil Nadu. Tuticorin port has been a centre for maritime trade and pearl fishery for more than a century. This natural harbour with a rich hinterland activated the development of the port, initially with wooden piers and iron screw pile pier and connections to the railways. The Port of Visakhapatnam is the Gateway to the east coast of India. It plays a crucial role as the middle-point distribution base for Southern, Eastern, Central and Northern states of India. The data collected on the wood imports were analysed following standard procedures.

### 3. RESULTS AND DISCUSSION

The data collected indicated that India imported wood from 62 countries through the five south Indian seaports from 2004-2009. Total quantum of 51.229 lakhs Cu. M. wood was imported through these ports during the survey period. Among the ports Chennai port imported 20.328 lakhs Cu. M. from 35 countries followed by Tuticorin imported 12.748 lakhs Cu. M. from 27 countries, Mangalore imported 9.534 lakhs Cu. M. from 22 countries and Visakhapatnam and Cochin ports imported 7.199 lakhs Cu. M. 1.4204 lakhs Cu. M. respectively from 16 countries each (Table 1). Among the countries, Myanmar is the major wood supplying country (39.67%) followed by Malaysia (13.12%), Congo (9.77%), Ghana (8.11%), Ivory Coast (8.01%), Benin (4.40%), Papua New Guinea (4.31%), Togo (3.00%), Cameroon (2.17%), Denmark (2.00%) and Germany (1.97%). Other African countries contributed less than one percent of wood supply to India through these seaports (Table 2). Among the wood species imported Teak logs, *Tectona grandis* was dominant with 45.93% followed by Gurjan logs, *Dipterocarpus* sp. 17.91%, Pyinkado logs, *Xylia* sp. 12.36%, Beech logs, *Fagus* sp. 9.72%, Maple logs, *Acer* sp. 8.29%, Merbau logs, *Instia* sp. 3.93% and remaining woods 1.86%. (Table 3). It indicated that teak is the most preferred species of usage in south India as reflected by the wood imports through these major five south Indian seaports. Teak (*Tectona grandis*) is one of the world's premier hardwood timbers, rightly famous for its mellow colour, fine grain and durability (Pandey and Brown, 2000). Its resistance to termites, fungi and other wood destroying agents is remarkable. This has made it very popular and there is regular demand by the Indian traders and consumers (Somaiya, 2005).

The countries, which are exporting teak to India, include, Myanmar, Malaysia, Thailand, Indonesia and many African and Tropical American countries. Somaiya (2005) commented that the list of countries supplying teak to India is exhaustive and thanks to the demand for teak in India that those countries are able to sell their products. The ever-increasing need for teak timber has resulted in large-scale plantations, both within and outside its range of distribution and it is a species of significant ecological and socio-economic importance throughout the tropics. The largest manufactures of teak products are Indonesia, Thailand and India (Katwal, 2005). It is clearly the most preferred timber species for production of high quality sawn wood and veneer. It has been found to be eminently suitable for multiple end uses and is as a reference species for end-use classification of a number of tropical hardwoods (Rajput and Gulati, 1983). The worldwide demand for teak is much greater than the available sources (Dupuy, 1990) and India is still the biggest market for teak only (Somaiya, 2005). As the indigenous supply of teak diminishes and the demand continues to increase, it is vital to grow teak towards increasing production. It is likely that teak continues to be the choice of Indians and will occupy top most position in solid wood usage in India.

### 4. ACKNOWLEDGEMENTS

The authors are grateful to Shri. S.C. Joshi, Director, Dr. B.N. Mohanty, Coordinator (Research) and Dr. O.K. Remadevi, Head, Wood Biodegradation Division, Institute of Wood Science and Technology, Bangalore for the facilities provided.

## 5. REFERENCES

Bell V.B, and Rand, P, 2006, *Materials for design*, Princeton Architectural Press, New York, pp 270.

Duncan, P, 2003, *The Development of the International Tropical Timber Organization and its Influence on Tropical Forest Management*, ISBN 9781853839917, Wastebusters Ltd, London, U.K., pp 290.

Dupuy, B, 1990, *Notes de voyage en Chine tropicale lors d'un seminaire regional sur le teck*, Bois et Forets des Tropics, 222, pp 69-76.

FAO, 2000, FAOSTAT Database. Food and Agricultural Organization of the United Nations, Website <http://apps.fao.org>.

Katwal, R.P.S, 2005, *Teak in India: Status, Prospects and Perspectives*, In *Quality timber products of Teak from sustainable management*, (Eds. Bhat, K.M., Nair, K.K.N., Bhat, K.V, Muralidharan, E.M. and Sharma, J.K.), Kerala Forest Research Institute, Peechi, Kerala, India, pp 669.

Lawson, G, and Hemery, G.E, 2007, *World timber trade and implementing sustainable forest management in the UK*, Report to the Woodland Policy Group, pp 84.

Pandey, D, and Brown, C, 2000, *Teak: a global overview*, *Unasylva*, 201, 51, pp 1-14.

Rajput, S.S, and Gulati, A.S, 1983, *Some considerations on the selection of reference timber for comparison in the evaluation of suitability indices of Indian Timber*, *Journal of Indian Academy of Wood Science*, 14 (2), pp 96-102.

Rao, K.S, 2002, *Current trends of wood use- an Indian perspective*, *Wood News*, 12 (2), pp 12-15.

Schultz, H, 1991, *The development of wood utilization in the 19th, 20th and 21st centuries*, *Forestry Chronicle*, 69 (4), pp 413-418.

Somaiya, R.T, 2005, *Teak trade in India*, In *Quality timber products of Teak from sustainable management*, (Eds. Bhat, K.M., Nair, K.K.N., Bhat, K.V, Muralidharan, E.M. and Sharma, J.K.), Kerala Forest Research Institute, Peechi, Kerala, India, pp 669.

**Table1. Detail of south Indian seaports in which the wood is imported.**

Sl. No.	Exporting Country	Seaport in which the wood is imported from 2004-2009				
		Chennai	Cochin	Mangalore	Tuticorin	Visakhapatnam
1.	Australia				+	
2.	Belgium	+	+		+	
3.	Benin			+		+
4.	Brazil	+				
5.	Cameroon	+		+	+	+
6.	Canada	+		+	+	
7.	Columbia	+			+	
8.	Congo		+	+	+	+
9.	Costa Rica	+				
10.	China	+		+	+	
11.	Denmark	+		+	+	
12.	ElSalvador	+				
13.	Ecuador					+
14.	Fiji	+				
15.	France	+	+	+		+
16.	Gabon	+	+	+	+	+
17.	Ghana	+	+	+		+
18.	Georgia	+				
19.	Germany	+	+	+	+	
20.	Guatemala					+
21.	Guyana			+	+	+
22.	Hungary					
23.	Indonesia	+	+		+	

24.	Italy	+	+	+		
25.	Ivory Coast	+	+	+	+	+
26.	Latvia	+				
27.	Liberia					+
28.	Madagaskar				+	
29.	Malaysia	+	+	+	+	+
30.	Myanmar	+	+	+	+	+
31.	Maldives		+			
32.	Netherlands				+	
33.	New Zealand	+		+	+	
34.	Nigeria	+				
35.	Panama	+				
36.	Papua New Guinea	+		+	+	
37.	Philippines				+	
38.	Poland		+			
39.	Portugal			+		
40.	Romania	+				
41.	Sierra				+	
42.	Spain	+				
43.	South Africa				+	
44.	Solomon Islands	+	+		+	
45.	Singapore	+		+		
46.	Srilanka			+	+	
47.	Sudan				+	
48.	Sweden		+			



49.	Taiwan					+
50.	Tanzania					+
51.	Togo			+		
52.	Tena	+				
53.	Thailand					+
54.	Turkey	+				
55.	Uganda			+		
56.	Uruguay		+			
57.	U.A.E.	+				
58.	U.K.		+			
59.	U.S.A.	+			+	
60.	Vietnam	+				
61.	Venezuela	+				
62.	West Africa				+	
	Total countries	35	16	22	27	16
	Total quantity of wood imported (Cu. M. lakhs)	20.328	1.4204	9.534	12.748	7.199

+ indicate wood imported

**Table 2. Major wood supplying countries and the quantum of wood imported in the south Indian seaports from 2004-2009**

Sl. No	Wood supplying Country	Wood supply (%)
1.	Myanmar	39.67
2.	Malaysia	13.12
3.	Congo	9.77
4.	Ghana	8.11
5.	Ivory coast	8.01
6.	Benin	4.40
7.	Papua New Guinea	4.31
8.	Togo	3.00
9.	Cameroon	2.17

10.	Denmark	2.00
11.	Germany	1.97
12.	Gabon	1.00
13.	West Africa	0.91
14.	Indonesia	0.83
15.	Guyana	0.73

**Table 3. Quantity of various wood species imported in South Indian seaports during 2004-2009.**

Wood species	Quantity (Cu.M.T in Lakhs) imported	Percent import
Teak logs, <i>Tectona grandis</i>	23.528	45.93
Gurjan logs, <i>Diptherocarpus</i> sp.	9.176	17.91
Pyinkado logs, <i>Xylia</i> sp.	6.331	12.36
Beech logs, <i>Fagus</i> sp.	4.982	9.72
Maple logs, <i>Acer</i> sp.	4.246	8.29
Merbau logs, <i>Instia</i> sp.	2.011	3.93
Others	0.955	1.86
Total	51.229	

# Engineered Wood for sustainable Design and Construction

Dr. Shantharam Patil<sup>6</sup> and Ms. Roshan Shetty<sup>7</sup>

## Abstract

*Architects, engineers and builders face significant challenges in the 21st century and among them, global environmental challenges must be a priority for our profession. On a planet with finite natural resources and an ever-growing built environment, engineers of the future must consider the environmental, economic, and social sustainability of structural design. Wood is the only building material on the planet which is naturally renewable, recyclable and leaves a lighter footprint than any other. Wood has a strong tradition in Indian culture and has always been one of India's major building materials. Thanks to its qualities and new technologies it is still one of the finest materials available to protect us and our environment. The main advantages are its physical and aesthetic qualities, workability, environmental sustainability, flexibility of space arrangement, dry construction, industrial production and comparative cost effectiveness. Wood works in accordance with nature and continuously inspires new directions in the design and construction of timber buildings. Excellent wood architecture, constant research and extensive experience with an understanding of timber construction make India one of the world's major wood architecture countries. As a construction material, it has been used very early next to stone, owing to its good material and mechanical properties. Different building types require different building component characteristics. To use them efficiently and economically a good understanding of the material, mechanical properties, structural and dynamical behaviour under various conditions are needed. This paper explores the properties and behaviour of timber in building structures and components. Although construction is never fully benign for the environment, designers and builders can make choices to minimize the impact. Wood plays an important part in sustainable design as shown by scientific analysis.*

**Keywords:** Engineered wood, Mechanical properties, Strength, Structural, Grain, Stress

---

<sup>6</sup> Associate Professor, MSAP, Manipal University, Manipal, India, spatilss@yahoo.com

<sup>7</sup> Assistant Professor, MSAP, Manipal University, Manipal, India, roshan22@yahoo.com

## 1. INTRODUCTION

Protection and shelter against wind, rain and cold is a very basic need for mankind. Since ancient times, wood has been the most important material used for this purpose. Wood is a traditional building material because of its strength, availability and low cost. It is readily available and inexpensive because it is a natural, renewable material. Compared to other building products such as steel, wood is easily manipulated and assembled on-site which saves time and money.

As a structural material, wood offers some key advantages over other materials in earthquake performance. Wood is strong and lightweight, hence ground accelerations do not generate as much energy in wood buildings as in other buildings. Traditional wood frame homes make use of many types of wood products such as studs, girders, joists, plywood, and trusses. The use of wood in many of the building's structural aspects allows the builder to save money without sacrificing strength or durability. Wood also gives flexibility to the builder to accommodate unique features and custom designs.

Wood can also be made into structural insulated panels (SIP-Figure 1). SIP's are a building material made of two wooden structural boards sandwiching an insulating material. Structural insulated panels have been used since the 1930's. Recently, SIP's have been becoming more and more popular. One reason is that they are a green alternative to the conventional use of studs and joists. SIP's are also very versatile as they can be used in residential, commercial and industrial. Another reason for their popularity is that less skilled labor and a lesser amount of time are needed to construct a building with SIP's than traditional lumber frame.

Structural insulated panels help improve the building envelope by providing greater thermal insulation. A building envelope, which includes the roof, walls, foundation, doors and windows, is the outer shield that protects a home from the environment. To provide a comfortable living environment, it is important to control the inside conditions from the outside conditions. To be reasonable, this has to be done in an efficient and cost effective way. SIPs help promote a tight envelope because they limit the amount of holes or entries for air to the inside or outside of the home. They also have a high insulating value with minimum thermal bridging which makes them ideal for extreme climate conditions. This results in a comfortable living environment. Structural insulated panels are used for walls, roofs, and floors. The structural faces are made of two oriented-strand boards (OSB) and the inner insulation is made of polystyrene, polyurethane or polyisocyanurate foam board.

The term "engineered wood products" is generally taken to refer to both materials and building elements fabricated with wood as a dominant material.

There are three broad groupings of engineered wood products:

**(i) Structural elements cut from board or linear forms of homogeneous material.**

Examples of these would be

- (a) slabs of Paralam, Scrimber, glulam, laminated veneer lumber,

(b) board material in the form of plywood, oriented strand board, laminated strand lumber and

(c) linear material such as finger-jointed lumber.

**(ii) Structural elements cut from slab, board or linear forms of composite material.**

Examples of these include

(a) boards of non-uniform layup,

(b) sawn hardwood end-joined by metal plate connectors and

(c) I-beams fabricated from a mixture of board and slab material.

**(iii) Composite elements fabricated as complete structural elements.**

Examples of these three types of engineered wood structural elements are illustrated in Figure 1.

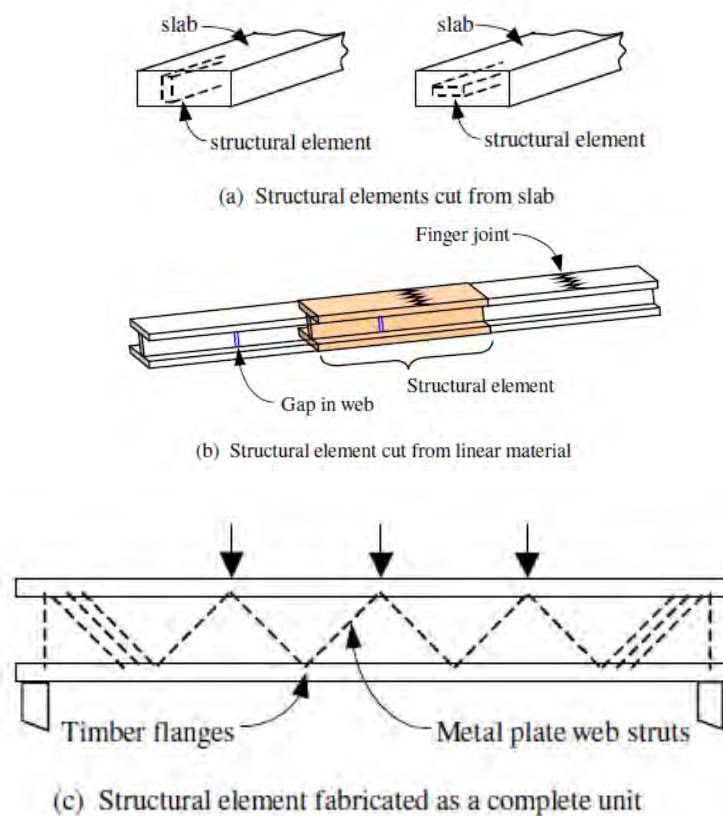

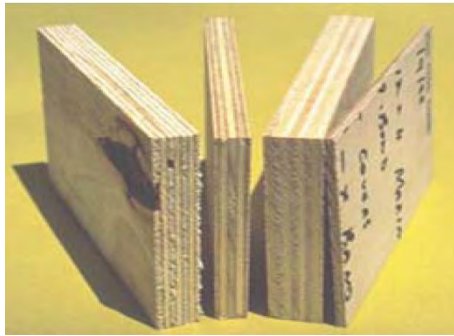

**Structural Plywood**



**Glue Laminated Timber**

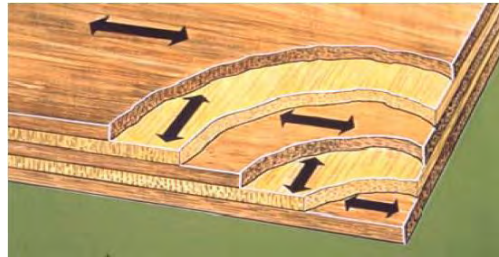

**Cross Lamination**



**Structural Laminated Veneer Lumber**



**Figure 1 Examples of Composite wood structural elements**

## 2. MECHANICAL PROPERTIES OF WOOD

Wood can be used in many popular structural forms from the light duty repetitive small structures to the larger and heavier framing systems used in commercial projects. Because wood has a high strength to weight ratio, dead load is a smaller component of the total load factor than for heavier material. Many mechanical properties of wood, such as bending and crushing strength and hardness, depend upon the density of wood; denser woods are generally stronger. Wood density is determined largely by the relative thickness of the cell wall and by the proportions of thick-walled and thin-walled cells present. The cells that make up the structural elements of wood are of various sizes and shapes and are firmly bonded together. Tiemann (1951) in his authoritative review of wood and other structural materials, concluded “weight for weight, dry wood without defect is stronger than steel. Because of its cell structure, wood has different strength properties in different grain directions and is therefore categorized as an anisotropic material. Different building types require different building component characteristics. To use them efficiently and economically a good understanding of the material properties, geometric properties

(aspect ratio, fibre orientation, stacking sequence – Figure 2), mechanical properties, structural and dynamical behaviour under various conditions are needed (Bodig and Jayne 1982). This paper explores the mechanical properties and behaviour of timber in building structures and components.

- Stress – It occurs when a load acts on a solid timber (column or beam). The force per unit area is called stress. Stresses – Tension, Compression and Shear (Figure 3 and Figure 4).
- Strain – The external forces deforms the shape and size of the timber. The change in length per unit of length in the direction of the stress is called strain.
- Bending – Determines bending tensile stresses, compressive stresses and shear stresses.
- Top half is under compression and bottom half is under tension. Maximum stresses are at upper and lower surfaces. No tension or compression at mid point – Neutral axis (Figure 5).
- There is a linear relationship up to the proportional limit. When stress is removed strain is completely recovered. Below the proportional limit ratio is constant – Young's Modulus (Figure 6).
- Tension strength parallel to grain – Important for bottom member (chord) in wood truss (Figure 7).
- Shear strength parallel to grain – Often determines of load capacity of short beam (Figure 8).
- Compression strength parallel to grain – Important in piles and columns (Figure 9).
- Compression strength perpendicular to grain – Important in design strength at connection strength between wood members and beam supports (Figure 10).
- Breaking strength (MOR) – Determines a load a beam will carry. MOR is accepted criterion of strength, although not a true stress as it is only true to the proportional limit (Figure 11).
- Toughness – Measure of amount of work needed to break small specimen by impact (Figure 12).
- Tension perpendicular to grain – Important in design of connections in buildings (Figure 13).
- Resilience – Measured by amount of energy absorbed when a timber is bent in the elastic range.
- Side hardness – Resistance to denting ( e.g. Flooring )
- Work to maximum load – Measure of energy of member as it is slowly bent.
- Modulus of elasticity (MOE) – Measure of resistant to bending (directly related to stiffness of a beams) also a factor in the strength of a long column.
- Modulus of elasticity parallel to grain (Young's Modulus) – Measure of resistance to elongation or shortening of a specimen under uniform tension or compression.

## Basic Wood Material Properties

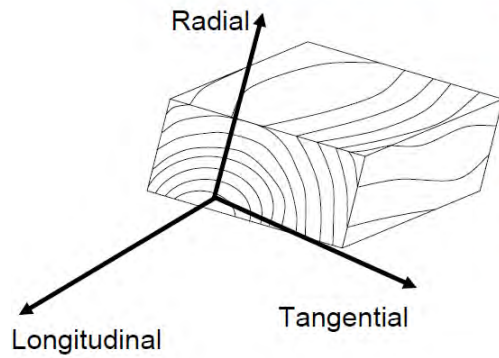

Wood is orthotropic

- Varies with moisture content
- Main strength axis is longitudinal - parallel to grain
- Unique, independent, mechanical properties in 3 different directions
- Radial and tangential are "perpendicular" to the grain - substantially weaker

Figure 2: Basic Wood material properties

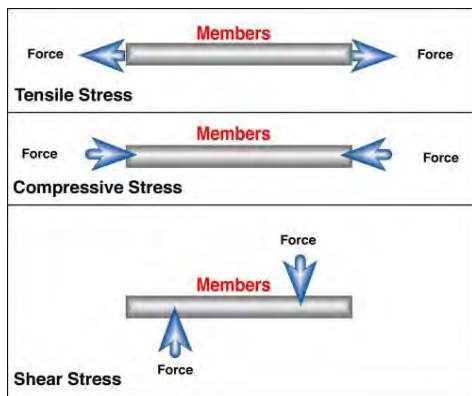

Figure 3: Forces on members

## Stresses

Tension



Compression



Shear



Figure 4: Stresses on members

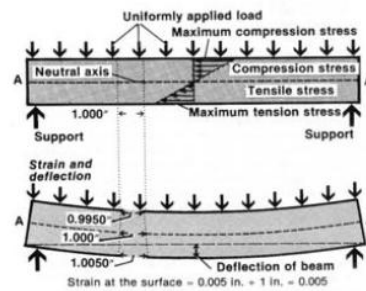
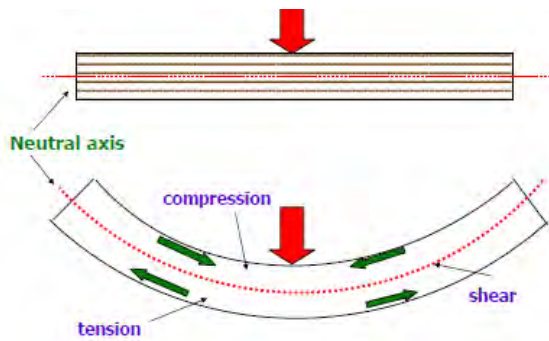
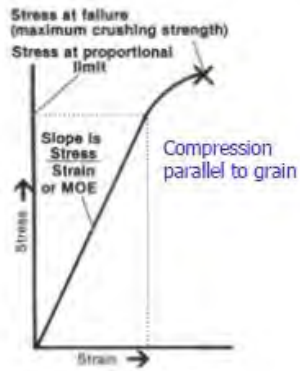
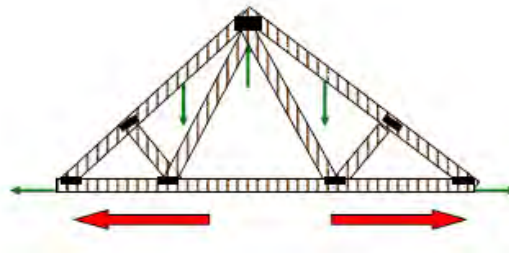

Figure 5: Bending

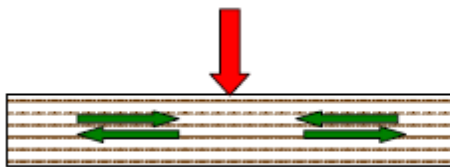



**Figure 6: Stress strain curve**



**Figure 7: Tension strength parallel to grain**



**Figure 8: Shear strength parallel to grain**



**Figure 9: Compression strength parallel to grain**

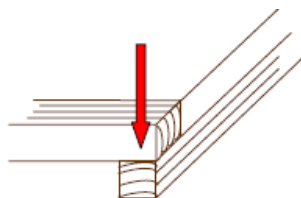

**Figure 10: Compression strength perpendicular to grain**

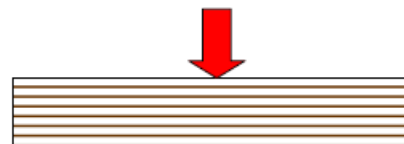

**Figure 11: Breaking strength perpendicular to grain**



**Figure 12: Toughness perpendicular to grain**

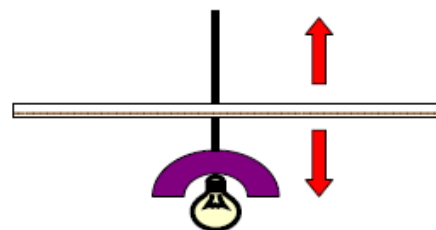

**Figure 13: Tension strength**

### **3. CONCLUSIONS**

Future research related to engineered performance technology is essential for accurate prediction of static and dynamic behaviour, product innovation and for trade. Product innovation is particularly important as a means of coping with changes in resources, changes in regulations related to environmental concerns and changes in competition arising from the introduction of new building systems. Additionally it is quite likely that there will be an increasing trend towards the development of many new composite structural systems that combine wood with other materials so as to optimise the use of the available building material resources.

### **4. ACKNOWLEDGEMENTS**

Manipal School of Architecture and Planning, Manipal University, Manipal, India, provided financial support.

### **5. REFERENCES**

Bodig, J. and Jayne, B.A. 1982. Mechanics of wood and wood composites. New York. Van Nostrand. P. 720.

Building Design + Construction, 2008: Using wood for sustainable design and construction, February, pp 61-72.

Leicester, R. H., Future directions of timber engineering research, NZ Timber Design Journal, 4(11), pp 7-16.

Roche, I. D. I., Dangerfield, J. A. and Karacabeyli, E., Wood products and sustainable construction, NZ Timber Design Journal, 1(12), pp 9-13.

Timber and Wood Products International Journal December 1999

Tiemann, H.D. 1951. Wood Technology: construction, properties and uses. London, Pitman, 1951. 3rd ed. P. 396.

## Abstract

Hairatjit Kaur<sup>8</sup> and Sangeeta Gupta

### Abstract

*Qualitative and quantitative features of shrub genera of 5 families viz. Caprifoliaceae, Loganiaceae, Melastomataceae, Myrtaceae and Oleaceae are studied to confirm the established relationship between wood anatomy and ecology. Moisture regimes of the genera are well revealed by Mesomorphy ratio, which incorporates vessel lumen diameter, vessel density and vessel element length. High Mesomorphy ratios were observed in genera from wet habitats in families: Melastomataceae and Myrtaceae. Low Mesomorphy ratios were obtained in shrub genera of dry habitats in families Caprifoliaceae, Loganiaceae and Oleaceae. Helical thickenings correlated with dry localities are found on vessel walls in Caprifoliaceae, Loganiaceae and Oleaceae. This aspect of correlation between wood anatomy and ecology can be used in reclamation of barren lands where ecology of the area can be used to decide the shrub genera to be planted in the concerned area.*

---

<sup>8</sup> Forest Research Institute, Dehradun, , INDIA (hairatjitsra@yahoo.co.in)

# Studies on Silviculture and Wood Utilization of the Most Expensive and Rare Rosewood Species in China

Liu Sheng-quan<sup>9</sup>

## Abstract

*Dalbergia odorifera* T.Chen, belonging to family of Leguminosae is the native species in Hainan province in China, what's more, it is the most expensive and rare rosewood species in China. The species is deciduous tree with smooth branchlets, coarse branches, alternating pinnate compound leaves, axillary panicle, ligulate oblong and swelling centrally pods. The tree is called heliophilous. High temperature and humidity can be favorable for the growth of this species. Propagation is achieved with seeds and cuttings. The heartwood can be formed within 5 years on average and is crimson, reddish-brown to deep reddish-brown with strong luster and dark brown or black strips. The grains are interlocked or swirls. The vessels, longitudinal parenchyma cells, fibers and xylem rays are all stratified. The beautiful ruleless figures are called grimace on the tangential section. Excellent wood properties and long-last spicy odor of the wood are overwhelming among various kinds of wood. So the wood has been used extensively especially like deep-dark and elegant furniture which can release aroma in persistence and last for hundred years without rotting. Moreover, this species can be of important medical use. With the decline of this species and the large market demand, more attention on the silviculture and utilization of the plantation of this species has been given in China.

**Key words:** *Dalbergia odorifera* T.Chen , Rose wood Species, silviculture, wood utilization

---

<sup>9</sup> Anhui Agriculture University, CHINA (Liusq@ahau.edu.cn)

# **The Technology of Modifying Fast-Growing Wood Used to Promote Higher-Value Wood Use and Sustainable development**

**Junwen Pu<sup>10</sup>**

## **Abstract**

*This article gives an extended introduction on the state of the art of wood modification worldwide.*

*The structural properties and biological durability determine the limits for the use of wood. Until recently, the only industrial applied method to improve the durability of wood was impregnating with toxic wood preservatives. Modification of wood aims at improving the durability in an environmentally friendly way, not by toxifying. Apart from durability, properties like dimensional stability, hardness and adsorption behaviour are also improved by modification. These improvements make wood an appropriate material in many more applications than untreated wood.*

*Fast-growing wood is treated with chemical agents in order to improve natural wood deficiencies, which can enhance the physical and mechanical performance, decay resistance, ageing resistance, fire resistance, and dimensional stability. It can also improve wood's color, texture, and increase value-added. Chemical modification is employed to overcome these drawbacks to the use of wood and transform it from an unpredictable material to high-value timber products with desired and predictable engineering performance.*

---

<sup>10</sup> Professor of Beijing Forestry University, CHINA (pujunwen@126.com)

# Wood from Eucalypt Plantation: One of the Most Sustainable ways to Resolve Wood Shortage Problems

Yaojian Xie<sup>11</sup>

## Abstract

*Eucalyptus as an exotic tree was first introduced into China in 1890. It was planted in parks as ornamental tree originally. However, until the 1950s, China only planted Eucalyptus mainly in Leizhou Peninsula and some places of southern Guangxi. Now eucalyptus has become one of the most important trees for developing fast-growing forest plantation in southern China. There are 3.6 million hectares of eucalypt plantation in China today, which are located mostly in Guangdong, Guangxi, Hainan, Yunnan and Fujian provinces. The development of eucalyptus plantation is still in expansion now and in the near future.*

*A huge amount of wood is consumed in China every year. According to the State Forestry Administration, 340 million m<sup>3</sup> of wood will be needed in 2015 in China, but the total wood production in China is only 190 million m<sup>3</sup>. So there will be a significant shortage of wood. How to resolve this problem? One of the best ways is to establish eucalypt plantations. It is estimated that by 2015, there will be 4 million hm<sup>2</sup> of eucalypt plantation in China. This means 60 million m<sup>3</sup> sustainable eucalypt wood can be produced per year, making an important great contribution.*

*Utilization of eucalyptus wood products is varied. Firstly, eucalyptus wood is used on a large scale for pulp making, about 2.0 million T pulp in southern China is made from eucalyptus wood every year, with new pulp mills soon to be opened. The second largest usage of eucalyptus wood is for artificial boards, includes fibra-board and plywood. The total production of artificial boards in China in 2007 was 74.0 million M<sup>3</sup>, which was No.1 in the world. China has the technology to use very small amounts eucalyptus wood ( $\Phi 6\text{cm}$ ) to make plywood. The third usage is for sawn timber. However, this is limited due to the scarcity of wide diameter eucalyptus trees in China. Almost all plantations are short rotation and produce only narrow diameter timber.*

---

<sup>11</sup> Professor of China Eucalypt Research Center, Chinese Academy of Forestry, CHINA (xieyj@21cn.com)

## White Cedar – The Wood of Royal Heritage

S.Mohan<sup>12</sup>, S.H.Jain, G.Ravikumar and K.Murugesan

### Abstract

*White cedar, scientifically termed as *Dysoxylum malabaricum* Bedd. Ex Hiern, and locally known as vellakil, purippa in Kerala; bilibudlige, bilidevadari in Karnataka and pureppa, vellaiyagil in Tamilnadu in southern part of India, is a top canopy tree species mostly found in Evergreen forests of Malabar, Anamalai and Travancore hills of the Western Ghats in India. The species is highly valued for its scented timber and proven medicinal value. It is used for making coconut oil casks. It is much sought after wood for paneling, joinery, cabinet making etc. Freshly felled timber gives a good fragrance. Wood contains oil, which is used for ear and eye disease. In some parts of Southern India White cedar wood is used for construction purposes such as beams, doors, windows, decorative paneling, tool handles, artificial limbs and rehabilitation aids, coorperage, chess pieces, mathematical and engineering instruments etc. A house constructed with this wood is considered to be indicative of the richness or the aesthetic sense of the person. In Kerala, a state in the southernmost tip of India, furniture and cabinets made of this prized wood are given to a bride as a token/ gift from parents to show the royal nature of their family heritage. It is believed that in most of the places of religious importance the bottom portion of the door frame is invariably made of this royal heritage wood. The artistic and cultural importance of white cedar wood is discussed in this paper.*

**Key words:** White cedar, *Dysoxylum malabaricum*, royal heritage, coorperage, decorative paneling

---

<sup>12</sup> Chemistry of Forest Products Division, Institute of Wood Science & Technology, Malleswaram, Bangalore-560003, INDIA (smohan@icfre.org)

## 1. INTRODUCTION

*Dysoxylum malabaricum* Bedd. Ex Hiern, belonging to the family Meliaceae, locally known as vellakil in Kerala, bilidevadari in Karnataka and vellaiyagil in Tamilnadu, is a lofty tree of the climax forests (Fig 1). It is commonly known as White Cedar. The tree grows up to 40 to 45 metres height and attains a girth at breast height (gbh) of about 4 to 5 metres. The trees are distributed in the Evergreen forests of Western Ghats from North Kanara southwards, ascending to 3000 ft. It tends to be gregarious and is frequently found in association with *Artocarpus hirsuta*. The sapwood is yellowish white and the heartwood brownish grey with yellow tint turning darker on exposing, usually faintly striped along the grain, straight or narrowly interlocked, grained, even and fine textured, lustrous and sweet scented. It is hard, strong, elastic and heavy. The specific gravity of the wood ranges from 0.64 to 0.81. The weight of the wood ranges from 46 to 48 lb/cu. ft. The wood is of great artistic and cultural important.



**Fig 1. *Dysoxylum malabaricum* Bedd ex Hiern., *Vella agil*, the scented wood of Western Ghats**

### 1.1 Cultural, Medicinal and Economic Value

White Cedar is a constituent of “ashtagandha”, which produce a fragrant smell. Wood is used for the production of incense sticks. It is also used in the absence of sandal. But there is no Sandal wood tree in a forest in which there is Vellakil (Nair and Nair, 1985). Vellakil is used to fumigate the “Yaga”, an offering to God and “Homa” centres. Fumigation of *Dysoxylum malabaricum* is very important in the “Oorukootam” or Kurichiya country. This tree is mainly seen in dense forests and sacred groves. In ancient times no one was ready to exploit the sacred groves as a part of the custom, because of that these trees are still protected.



Decoction of wood is useful in arthritis, anorexia, cardiac debility, expelling intestinal worms, inflammation, leprosy & rheumatism (Kumar, 2005). Flavopiridol, although being a totally synthetic compound, has as the basis of its novel flavonoid structure a natural product, rohitukine, isolated as the constituent responsible for anti-inflammatory and immunomodulatory activity from *Dysoxylum binectariferum* Hook.f.(Meliaceae), which is phylogenetically related to *Dysoxylum malabaricum* Bedd. Flavopiridol is one of the over 100 analogs synthesized during structure-activity studies, and was found to possess tyrosine kinase activity and potent growth inhibitory activity against a series of breast and lung carcinoma cell lines (Sausville et al., 1999). Wood oil is used in treating ear and eye disease (Jain and Dafilips, 1991). In Sidha, the plant is known as Agil and is used as a substitute for *Aquilaria malaccensis* (Kumar, 2005).

The timber of white Cedar is highly reputed. The wood is an important constituent in the perfumery and plywood industry. The wood is also used for making motor truck bodies, furniture, carts, railway carriages, Toys and textile wooden accessories like bobbins (Gopimani (1991), It is used for the frame work of carts and carriages.

## **1.2 Other uses of the White Cedar wood**

White Cedar is primarily used in the west coast of India for cooperage. It is eminently suited for making casks required for storing and transporting coconut oil, as it does not discolour the oil or allow it to percolate through. It is much sought after wood for paneling, joinery, cabinet making etc. Freshly felled timber gives a good fragrance. In some parts of Southern India, especially in Kerala, White Cedar wood is used for construction purposes such as beams, doors, windows, photo frames, tool handles, artificial limbs and rehabilitation aids, chess pieces, mathematical and engineering instruments etc. A house constructed with this wood is considered to be indicative of the richness or the aesthetic sense of the person. In Kerala, a state in the southernmost tip of India, furniture and cabinets made of this prized wood is given to a bride as a token/ gift from parents to show the royal nature of their family heritage. It is believed that in most of the places of religious importance the bottom portion of the door frame is invariably made of this royal heritage wood.

## **1.3 Use of White Cedar wood in snake bite treatment in Kerala**

The Kani tribe of the Western Ghats of Kerala applies 'Vishakallu', a medicated stone with anti - poisoning properties to the affected area (snake bite). The ingredients that go into the making of 'Vishakallu' are pebbles from the river, Tulsi or Holy Basil leaves (*Ocimum sanctum* - Lamiaceae), Leaves of Perumthumba (*Anisomeles malabarica* - Lamiaceae), Heartwood of Chandanam (*Santalum album* - Santalaceae), *Dysoxylum malabaricum* (Vella Akil- Meliaceae).

### **Mode of preparation of 'Vishakallu'**

Pebbles are ground, mixed with the other ingredients and made into paste and wrapped with 7 leaves of *Aristolochia tagala*. It is baked on fire made by burning wood of Chuvannakil (*Chukrasia tabularis* – Meliaceae; native to India and Sri Lanka ) *Dysoxylum malabaricum* (Vella Akil- Meliaceae), or sandalwood, holy basil and camphor. This baked cake is covered with paste of termite mound soil and again

baked on a low fire. The soil coat is removed and the cake is soaked in water for an hour, covered with paste of *Pittosporum neelgherrense* - Analivegam (Pittosporaceae) stem bark. The whole thing is baked again and covered with stem bark of *Kunstalaria keralensis* (Fabaceae) and sun dried. This 'stone' is stored in burnt cow dung ash and *Nicotiana tabacum* - Pukayila (Solanaceae) leaves (Tobacco).

### **Mode of administration of 'Vishakallu'**

It is administered only by experienced tribal healers. The stone is directly applied to the bitten part. It sticks there and absorbs the venom from the wound. During this operation, Lord Siva is propitiated by chanting mantras. When all the venom is absorbed the stone falls away automatically. The stone is immersed in cow's milk for detoxification for 2 hours. It is again dried and stored in cow dung ash. It is believed from experience that it can be used 20 times.

### **1.4 Chemistry of White Cedar Wood**

No work on the chemistry of the wood has been reported so far but for a recent research study by Mohan S et al., (2010) to know the chemical compounds of *Dysoxylum malabaricum* wood. It was found that the wood powder on hydro-distillation yielded an essential oil (0.60%w/w). GC-MS analysis of the oil showed the presence of 63 compounds of which 24 have been identified amounting to an area of 80.21 % and 35 unidentified compounds (19.79%) with less than 0.1 % area. The major component is  $\alpha$ -Muurolene (11.75%) along with 10 components which are more than 2.5% in composition namely T-Muurolol (5.08%),  $\delta$ -Cadinene (4.75%), Hexa hydroxy Naphthalene (4.14%), Benzene[1-chloro-4(1-methylethyl)](4.06%), Azul [1,4 dimethyl-7-(1-methylethyl)](3.82%), 1,4-Cyclohexadiene(3.73%), Viridifloral (3.23%), T.Cadinol (3.06%),  $\alpha$ -Elemene (2.99%) and  $\alpha$ -Copaene (2.51%).

$\alpha$ -Muurolene, the major compound is used in the manufacture of flavouring agents and food industry especially in dairy products, fats and fat emulsions, confectionery, cereal and cereal products, meat and meat products etc. The high content of  $\alpha$ -Muurolene i.e 11.75% in *D.malabaricum* makes it a very good source for this compound.

## **2. CONCLUSION**

It is seen that the traditional and aesthetic value of White Cedar wood is well known. White cedar wood has got cultural, medicinal and many other uses. Recently chemistry of the wood essential oil has been studied and an important compound used in the manufacture of flavouring agents has been identified. The regeneration of this species from seeds is very low, leading to dwindling forest populations. Concerted efforts should be made by research organizations and forest departments to study the chemistry and regeneration of this economically important wood.

### 3. REFERENCES

Gopimani, R. 1991 Sasya sabdavali. Kerala Agricultural University, Mannuthy (In Malayalam)

Jain S.K and Dafilips A Robert 1991 Medicinal Plants of India vol.2 Reference publication, INC, Michigen

Nair P.N. and Nair C.S.1985 Keralathile Vana Sasyangal, Kerala Bhasha Institute, Thiruananthapuram, Kerala

Kumar Vinod, R., 2005. Keralathile Vanavrukshangal, DC Books, Kottayam (In Malayalam)

Sausville, E.A.,Zaharevitz, D., Guassio, R., Meijer, L., Louarn-Leost,M., Kunick, C.,Schultz, R., Lahusen, T., Headlee, D., Stinson, S., Arbuck, S.G.,1999. Cyclin-dependent kinases, initial approaches to exploit a novel therapeutic target. Pharmacology & Therapeutics 82,285.

S. Mohan, R. Ezhumalai, S.H.Jain and G.Ravikumar 2010. Chemical constituents of the essential oil from *Dysoxylum malabaricum* Bedd. wood of Western Ghats, Journal of the Indian academy of wood sciences. Vol 7(1 & 2), 71-74

# Sandalwood - History and Chemistry in the Art and Joy of Mankind

S H Jain<sup>13</sup>, G Ravikumar, C Sowmya, S Mohan and K Murugesan

## Abstract

“Chandana”, the Sanskrit name ascribed to *Santalum album* Linn, was known and used in India from earliest historic time, before Christ, the Ramayana and Mahabharata. Sandalwood has been intimately associated with human civilization since time immemorial. It has fascinated artists and craftsman, this wood is nature’s gift to mankind. Vedas and puranas are the oldest codified literature in Indian context and such treatises quote uses of sandalwood for medicinal and cosmetic purpose. Essential teachings of Jainism and Buddhism schools too advocate oral and external uses of sandal. Kautilya’s text on ancient Indian economics considers sandalwood as precious forest product. Sanskrit text of the medieval period throw light even on the quality tests, classification and types of sandal. Sandalwood oil is one of the oldest known perfume materials with 4000 years of uninterrupted use. The fixative property and tenacious aroma of its oil is due to presence of major odoriferous sesquiterpenic alcohol -  $\alpha$ -santalol and  $\beta$ -santalol, (70-90%), and thirty other minor/trace compounds. It is synergistic of a specific combination of all major and minor constituents naturally present in sandalwood oil that give its valuable woody, sweet fragrant and persistent odour. The human olfactory nerves are specific to the scent of the santalols. If the chirality (arrangement of the atoms in the molecule) of the santalols is changed to the molecule’s mirror image, the human nose cannot detect the fragrance. Apart from its importance as a supreme satisfying source of fragrance, it finds use in not only in religious purpose, but also healing, particularly in management of mental disorders. Pre-Christian era Indian medicinal texts like the Charaka Samhitha along with later texts such as the Asthanga Samhitha make thorough reference to sandal use. In the modern patent era it is essential to look into its medicinal properties such as anti-herpes, antiseptic, antipyretic, diuretic, stimulant and for treatment of bronchitis, dysuria, gonorrhoea and urinary infections etc. Drastic decline in production and high price of sandalwood have restricted its utility in recent decades. The importance of chemical constituents of sandalwood oil, its role in the history of utility by mankind and market trend is discussed in this paper.

**Key words:** Santalum album, mankind,  $\alpha$ -santalol and  $\beta$ -santalol, fragrance

---

<sup>13</sup> Chemistry of Forest Products Division, Institute of Wood Science & Technology, Malleswaram, Bangalore-560003, INDIA (shjain@icfre.org)

## Abstract

S Mohan<sup>14</sup>, G Ravikumar, S H Jain, Pankaj Aggarwal and S C Joshi

### Abstract

*In India, socio-economically significant and ecologically important trees are considered very sacred and worshipped. Vedic traditions established the principles of ecological harmony since ancient times – not because of the imminent environmental disaster, but for the spiritual healing and physical association with better ethical awareness and moral responsibility. Red Sanders (*Pterocarpus santalinus*) is one such species which has been of great importance in India since time immemorial. In the past, red sanders wood was used for carved and decorated pillars in many towns in India. Its significance can be understood by the fact that still it is found in most of the houses in the villages of India. The heartwood of red sanders is carved into vessels and statuettes. The high quality red sanders is widely used domestically to make furniture and carvings, agricultural implements, poles, carts and picture frames, and carved house posts. In South India, there is a great tradition and culture and long standing history, wherein a pair of doll (male and female) made up of red sanders is compulsorily presented to the married couple even today. The wood powder is also used as a facial mask and is believed that it rejuvenates and makes the skin glow. Heartwood of red sanders has a great demand in foreign markets. The export value of the wood was rediscovered almost in 1940s when Japanese found in a certain class of timber a special quality ideally suited for the manufacture of a popular musical instrument called 'Shamisen', traditionally presented to a newly wedded couple. In the 1930s, Japan commenced to import Indian red sandalwood (red sanders) for the manufacture of the traditional shamishen musical instrument and this market remains important today at a level of several hundred tonnes per annum. The traditional significance (art), cultural values (joy) of red sanders wood is discussed in this paper.*

**Key words:** Red sanders, carvings, heartwood, cultural and shamishen

---

<sup>14</sup> Malleswaram, Bangalore-560003, INDIA (smohan@icfre.org)

# Wood Artifact vis-a-vis Plantation Timbers

H C Nagaveni<sup>15</sup> and O K Remadevi

## Abstract

*Timber art and exclusive timber furniture manufacturers offer a design service that can create innovative designs to suit individual taste, whims & fancies. Woodcraft and furniture of aesthetic value is principally manufactured by primary timbers. As these species are fast depleting due to tremendous increase in daily needs, plantations help to substitute the source of timber. Plantation grown timbers are already in use for various purposes such as sculptures, religious artefact, furniture and other building material, etc. Fast grown plantation species have different timber characteristics including their resistance against biodegrading agents from that of the same species grown in native forests and it is vital to know their decay resistance before putting in to use for the specific purpose, which adds more value for plantation timbers.*

*In this connection, durability against decay fungi and termites of different age group of *Acacia auriculiformis*, *A. mangium*, *Grevillea robusta*, *Eucalyptus terreticornis*, *Maesopsis eminii*, *Melia dubia*, *Ailanthus malabaricum* and *A. excelsa* from plantation have been evaluated. Eight-year-old *Tecomella undulata* grown under a social forestry programme in Tamil Nadu has been evaluated for natural durability and it was found that heartwood is resistant to fungi as well as termites at this age which may be used for timber and other woodcraft work as mature wood. Ten years and above aged trees of *Acacia auriculiformis* and *E. terreticornis* were durable and may be used making wood artifacts without any problems of biodeteriorating agents. Probable uses of other tested plantation species vis-a-vis age are given in detail depending on their resistance against biodeteriorating agents.*

**Key words:** Durability, decay-resistance, decay fungi and biodeterioration

---

<sup>15</sup> Institute of Wood Science & Technology, Malleswaram, Bangalore-560003, INDIA  
(hcnagaveni@icfre.org)

## 1. INTRODUCTION

The natural forests used to be the only source of commercial timber in tropical timber producing countries. In the past several years however, governments have begun implementing strict conservation policies, which have curtailed the harvest levels from the fast depleting natural resource base. To meet their respective wood requirements and at the same time to re-vegetate denuded areas, most tropical countries have started to embark in tree plantation programs. Trees in plantations grow fast because of intensive management. These plantations help to reduce the environmental impact of cutting trees for timber. Plantation timbers are environmentally sustainable, as no actual forest has to be cut down for it. There are several countries where forest plantations are highly important in the provision of goods and services. Worldwide, an estimated 15% of plantations in tropical countries are established to reduce the pressure of natural forest.

Countries which are among the largest plantation nations in the world include India (3.2 million ha), New Zealand and the United Kingdom (1.9 million ha each), Australia (1.8 million ha), Malaysia (1.6 million ha) and South Africa (1.4 million ha). Ninety nine per cent of New Zealand's industrial wood came from plantations in 1997 (FRA, 2000), and industrial wood products are the third largest export. The most readily available plantation timbers in many countries are softwoods such as Hoop Pine, Radiata Pine and Slash Pine. It was erroneously believed for decades that radiata was the only commercially viable species that could be cultivated here. Of late, many tree species are grown as plantation including Teak, Eucalypt, Acacia species etc. In India, Sri-lanka, Indonesia, Malaysia, Thailand and other Southeast Asian countries, rubber-wood obtained from plantation after extracting latex are put to use for various purpose such as door and window profiles, matting, flooring and furniture. Use of rubber wood as timber for a range of purposes has made revolution in wood industry.

As customary timber's availability is in short supply, several species of plantation timbers are already used for different purpose including wood-artifacts. But, their uses are limited as plantation timbers are fast growing and they have the problems of fungal attack, especially when exposed in humid conditions. The information on some of the common plantation timbers available in Karnataka, their role in artifacts and durability against fungi is discussed in the paper.

### Methods and materials

Timber from 5, 10, 15 and 20 year old plantations were procured both from low and high rain fall area, converted in to test samples and they were exposed to wood decay fungi as per IS standards (IS-4873). After assessing the decay loss, timber species were grouped under different durability class (Bakshi, 1967 and ASTM, 1981). Species taken for test were *Acacia auriculiformis*, *A. mangium*, *Grevillea robusta*, *Eucalyptus terreticornis*, *Maesopsis eminii*, *Melia dubia*, *Ailanthus malabaricum* and *A. excelsa*.

## Availability of plantation timbers and their uses

*Acacia auriculiformis*, *A. mangium*, *G. robusta*, *E. terreticornis*, *M. eminii*, *M. dubia*, *A. malabaricum* and *A. excelsa* are grown in Karnataka and different age group of timbers is available in Karnataka and also elsewhere in India. Their main uses as timber and additional use for wood-artifacts are given in table-1 and their durability against decay fungi is given in table-2.

*A. auriculiformis* and *A. mangium* plantations came up in the beginning to serve the purpose of fuel, as they had good calorific value. Slowly, it found its place in the pulp and paper industry and packing cases. Recently, it is also recognized for tools & tool handles, sports goods and artistic furniture and other handicraft work. Timber of this species is durable (table-2) (Nagaveni *et al*, 2002). Though there is little variation in their weight loss against decay fungi with different age group, all 4 age groups of timber come under resistant class (class-I) as per Bakshi, 1967 and ASTM, 1981.

Between two *Ailanthus* species, *A. excelsa* is a perishable timber against decay fungi (class-IV) and *A. malabaricum* falls between resistant to moderately resistant groups (II & III) (Venmalar *et al*, 2011). But these species are used in handicraft, to prepare cheap quality toys and cricket bats. Eucalyptus species have durable wood. But young plantation timber of 5 and 10 year old timber comes under resistant group (II), where as mature wood from above 15 year old plantation showed very good resistant against decay fungi (Class-I). Timber used for many handicraft works including good carvings.

The *G. robusta* tree produces an attractive and easily worked wood for veneers, ornamental paneling and parquet floors in the world furniture trade where it was marketed as “lace-wood” and this timber also used for other small handicraft work. It is a moderately durable timber (III & II).

Timber of *M. eminii* is grouped under non-resistant to moderately resistant group. Wood is used for light construction, boxes and crates, picture, slate frames, plywood and also used handicrafts and some furniture. *M. dubia* timber is grouped under non-resistant to moderately resistant class (IV & III). Wood is used for pulp, packing cases, cigar boxes, ceiling, planks, veneer industry, tea boxes, and ply-board, agricultural implements, pencils, matchboxes, splints, kattamarams, musical instruments. This wood is also used for furniture, small toys.

*T. undulata* is one of the species used for various artifact products such as drums, carvings, furniture, artistic turning, handicrafts, idols and idol base, photo frames in addition to agriculture implements. This is an important indigenous tree species found in the hot desert areas of Rajasthan State in India known as Marwar teak. This tree is grown in different states as plantation. Wood from 8 year old plantation grown in Tamil-Nadu was tested for its durability against decay fungi and results showed that wood is highly durable even at 8 year old plantation (Nagaveni *et al*, 2002).

Conventional species of timber were used for various utility were obtained from natural forest, when they were available in plenty. Of late, due to paucity of wood, it is enforced to utilize plantation timbers for various purposes. In different countries the practice of utilizing plantation timbers are well known. In many European countries,



timbers were procured only from plantations, which were exclusively grown to meet the demand of timber. Forest plantations were originally established to provide industrial timber, mainly in those countries, such as South Africa or the United Kingdom, which had a small natural forest estate. But since the mid-1980s forest plantations have assumed greater importance as a source of wood in almost all countries, whatever their forest cover is less, thus often taking pressure off from the natural forest.

According to a 2007 sustainability report issued by the Ministerial Conference for Protection of Forests in Europe (MCPFE), plantations cover about 16 million hectares, or 7.9% of the total forest area in Europe excluding the Russian Federation. These intensively managed tree crops are important for wood production in several countries and form a very large share of forest area in Ireland (85%), the UK (55%), and Denmark (62%). Plantations also account for more than 10% of the forest area in Belgium, Luxembourg, Portugal, Belarus, Turkey, France and Albania. Plantation areas in Europe are increased by 2.8 million hectares in the period 1990 to 2005 at an annual rate of 180,000 hectares. A key trend in the forest sector of North America and increasingly, in Europe in recent years, has been growing interest in timberland as a potential private sector investment.

In Australia, Churches, homes, sculptures and religious artifacts, and fine furniture pieces are all handmade and have all been carved with only plantation timber exclusively of mahogany and teak by Fine Woodcraft Gallery. Australia Fine Woodcraft (established 1970), was awarded the Western Australian Hall of Fame Award in 2000. Ninety nine per cent of New Zealand's industrial wood came from plantations in 1997 (FRA, 2000), and industrial wood products are the third largest export.

India (3.2 million ha) is among the largest plantation nations in the world. Different tree species are grown to meet demand. Understanding durability and management of decay helps to add the value for the plantation timbers and is an effort to retain the footprint of wood-arts, without compromising on the style and beauty of each item.

## **2. REFERENCES**

Anon 1981. Standard method of accelerated laboratory test of natural decay resistance of woods. ASTM: D 2017-81.

Bakshi, B.K. 1967. Accelerated laboratory investigation on durability of wood. Final technical report, FRI & Colleges, Dehradun. 57pp

Anon, 2006. FAO, 2006c report. <http://www.fao.org/forestry/site/aliens/en/>

Anon, 2009. Wood Products Prices in The UK , Europe and North America. [http://www.globalwood.org/market/timber\\_prices\\_2009/aaw20090802e.htm](http://www.globalwood.org/market/timber_prices_2009/aaw20090802e.htm)

Anon, 2011. Common wealth forestry, 2010. <http://www.cfa-international.org/CWF/CWF-686.htm>

Nagaveni, H.C., O.K. Remadevi, M.N. Sharma and R.V. Rao. 2002. Studies on the durability of plantation grown *Tecomella undulata* (sm) SEEM. T.D.A., 48 (1&2): 32-36.

Nagaveni. H.C., and G. Vijayalakshmi and O.K. Remadevi 2007. Natural resistance of *Acacias* species against wood decay fungi. Journal the Indian Academy of Wood Science. N.S. 4 (1&2): 35-39.

Nagaveni, H.C., G. Vijayalakshmi, D. Venmalar and O.K. Remadevi, 2011, Durability of *Grevillea robusta* of different age-groups grown in dry and wet region. Presented in 'New Frontiers and Future of Wood Science and Technology in India' on Jan, 2011 at IWST, Bangalore.

Venmalar D., H.C. Nagaveni, O.K., Remadevi, G. Vijayalakshmi, P. Shalini and P. Babu 2011. Durability of wood from different age groups of *Ailantus excelsa* and *A. malabaricum*. Presented in 'New Frontiers and Future of Wood Science and Technology in India' on Jan, 2011 at IWST, Bangalore

**Table-1. Main uses of timber with additional use for wood-artifact**

	Species	Main uses	Artifact uses
1	<i>Acacia auriculiformis</i>	Paper, furniture, tools & tool handles, packing cases Sports goods	Handicraft, furniture
2	<i>Acacia mangium</i>	Paper, furniture, flooring, decorative veneer, MDF, particleboard and fuel wood.	Handicraft, decorative veneer, Cabinets, turnery, floors
3	<i>Ailanthus excelsa</i>	Matchwood boxes and match splints, Packing cases, Catamarans	Sword handles, Spear sheath, cottage industries for making wooden toys and cheap quality cricket bats
4	<i>Ailanthus malabaricum</i>	Match splints,	Decorative veneer used in religious functions as dhoop, and in the incense stick and perfume industry
5	<i>Eucalyptus terreticornis</i>	Construction, furniture, Slate frames	Furniture, handicrafts and carvings.
6	<i>Grevillea robusta</i>	Furniture, packing cases, flooring, paneling, plywood and the manufacture of small wooden items such as bobbins and pencils	Furniture, Toys, ornamental paneling, parquet floors and handicrafts.
7	<i>Maesopsis eminii</i>	Light construction, boxes and crates, picture, slate frames, plywood.	Handicrafts and furniture. Bark is used in the Congo region as a roofing material
8	<i>Melia dubia</i>	pulp packing cases, cigar boxes, ceiling, planks, veneer industry, building and construction materials, agricultural implements, pencils, matchboxes, splints, kattamarams, musical instruments, tea boxes, and plyboard, outriggers for boats. It is also a good fuel-wood	Furniture, small toys.
9	<i>Tecomella undulata</i>	Agriculture implements, furniture	Drums, carvings, furniture, artistic turning, handicrafts, idols and idol base, photo frames

**Table-2. Plantation timbers of different age and their durability against decay fungi**

Timber age	<i>A. auriculiformis</i>		<i>A. mangium</i>		<i>A. excelsa</i>		<i>A. malabaricum</i>		<i>E. terreticornis</i>		<i>G. robusta</i>		<i>M. eminii</i>		<i>M. dubia</i>		<i>T. undulata</i>	
	Value	Class	Value	Class	Value	Class	Value	Class	Value	Class	Value	Class	Value	Class	Value	Class	Value	Class
5 Yrs	10.5	I	10.8	I	45.8	IV	29.9	III	21.5	II	20.95	II	45.87	IV	45.8	IV		
10 Yrs	10.5	I	9.5	I	45.6	IV	25.5	III	17.9	II	17.04	II	42.19	IV	34.5	III		
15 Yrs	7.9	I	7.2	I	43.7	IV	13.7	II	6.55	I	14.75	II	27.42	III	22.5	III	-	-
20 Yrs	6.9	I	5.9	I	38.7	IV	11.2	II	5.85	I	10.77	II	26.93	III	20.5	III	-	-

# Picking From a 'Wood-getable' Market

Shakti Singh Chauhan<sup>16</sup>

## Abstract

*Wood is, and will remain, important to human society. The current trends of depleting natural forest resources and shrinking choices for various end-uses are promoting multiple uses of fast-grown plantation timber. Today, forest plantations have become the major source for solid wood, engineered wood, wood based composites, and pulp and paper applications. With the remaining primary forests being dedicated to conservation, the trend is expected to continue in the future too. It is also imminent that the luxury of using different species for different end uses will be replaced by multiple uses for the same species. At this juncture, it becomes critical to exploit the full breadth of variability in the plantation species to suit various applications. One way of addressing the issue is to exploit inherent variation in wood quality traits (density, stiffness, shrinkage, fibre dimensions, microfibril angle, chemical composition etc.) to tailor trees for specific end uses. However, prior to achieving this target, the approach should be to segregate available material according to their suitability for specific end uses. Today, the market is full of apparently identical but inherently variable material, which when converted into products affects product performance and consumer satisfaction ultimately. Consequently, an adverse psychological drive of 'bad wood' can permeate through the society. It is important to recognise that there is no bad wood; it is just ignorance, improper processing and poor end-use selection. In this conference I will emphasize on adaptable approaches for segregating wood for different end-uses.*

---

<sup>16</sup> Institute of Wood Science & Technology, Malleswaram, Bangalore-560003, INDIA (shakti@icfre.org shakti32@gmail.com)

# Insect Invaders Subduing the Art and Joy of Wooden Assets in India

O K Remadevi<sup>17</sup>

## Abstract

*Wood as a material is very durable and in sheltered environments it can last undiminished for thousands of years, imparting ambience, glamour and joy. Being a structural material, wood is shaped and articulated into our livelihood needs such as wardrobes, cots, tables, dressing tables, chairs etc. In India various wood products are manufactured from the sapwood as well as heartwood of durable and also non-durable commercial species. Timber in the finished articles or wooden structures in buildings is highly prone to insect attack in Indian conditions. Wood boring insects have become rampant in the recent past due to large scale use of untreated secondary perishable timber species.*

*In India, the handicraft industry is considered the second largest industry next to agriculture. Many skilled artisans have adopted wood crafting as their livelihood, carving out beautiful artifacts from diverse timber species. The attack by powder post beetles diminishes their value in both the national and international markets. The wood packing industries in India, consume 6.81 million m<sup>3</sup> of wood for packing fruits, vegetables, tea, tobacco, textiles and machinery. Since the government has imposed a ban on the felling of trees in natural forests, many short rotation timbers and exotic timbers are being used. Powder post beetles which attack sapwood comprise the lyctid, bostrychid, anobid and cerambycid beetles. These are the most common pests in the household furnitures and wardrobes, which are made of plywoods and blockboards. The pest problems are due to ignorance, negligence or poor management. As a result, insects enjoy wood as their food and abode and the art and joy of wood is a function of insect dominance. They diminish the life and worth and subdue the art and joy of wooden assets in India.*

---

<sup>17</sup> Institute of Wood Science & Technology, Malleswaram, Bangalore-560003, INDIA (okremadevi@icfre.org.org okremadevi@gmail.com)

# Wood Identification of Expensive Woody Art Collection Mostly Expensive Religious Images Deposited at San Agustin Church, Intramuros, Manila

Arsenio B Ella<sup>18</sup> and Emmanuel P Domingo<sup>19</sup>

## Abstract

*Identification of expensive religious images like wooden religious statues from the wood art collections of PAGREL Museum deposited at San Agustin Church, a UNESCO World Cultural Heritage in Intramuros, Manila was conducted following request from the owner of the museum.*

*As the statues were painted, identification was based principally on the structure of the wood. The primary problem that was encountered in the course of wood species identification was how to locate the true cross section of the object. A cut was made in a portion that would not mark the appearance of the statue. In many instances the base part of the statues is curly grained, possibly obtained from a buttress or some are in advanced state of decomposition. In a few instances, some component parts have been replaced with different species.*

*Among the principal species identified were those of molave (*Vitex parviflora* Juss.), batikuling (*Litsea leytensis* Merr.), narra (*Pterocarpus indicus* Willd. forma *indicus*), makaasim (*Syzygium nitidum* Benth.), santol (*Sandoricum koetjape* (Burm. f.) Merr.), marango (*Azadirachta excelsa* (Jack) Jacobs), kamatog (*Sympetalandra densiflora* (Elmer) v. Steen.), batitinan (*Lagerstroemia pyriformis* Koehne forma *batitinan* (Vidal) Furt. & Sris.), dungon (*Heritiera sylvatica* Vidal), acacia (*Samanea saman* (Jacq.) Merr.), and a miscellaneous species, malapingan (*Trichadenia philippinensis* Merr.). A total of 60 statues were identified. Furthermore, a short write-up on woods for their catalogue was received and corrections were made particularly on the existing binomial of the species.*

**Keywords:** wood identification, religious images, statues, San Agustin Church, Intramuros UNESCO World Heritage

---

<sup>18</sup> Forest Products Research and Development Institute (FPRDI), Department of Science and Technology (DOST), College, Laguna 4031, PHILIPPINES (Arsie\_Ella@yahoo.com)

<sup>19</sup> Research Assistant, FPRDI-DOST, College, Laguna 4031 Philippines, emandomingo@ymail.com

## INTRODUCTION

The San Agustin Church is the oldest existing church in the Philippines, and was originally built in 1571. It is an essential tourist destination in Manila for those who are interested in Philippine history and culture. The present structure is actually the third to stand on the site. It has 14 side chapels and a *trompe-l'oeil*. Up in the choir loft are the hand-curved 17<sup>th</sup> century seats made of molave (*Vitex parviflora* Juss.), a beautiful tropical hardwood.

The San Agustin Church lies inside the walled city of Intramuros located in the capital city of Manila. It is the first European stone church to be built in the Philippines designed in a Spanish architectural style. It also houses the legacies of the Spanish conquistadores, Miguel Lopez de Legazpi, Juan de Salcedo and Martin de Goiti who are buried in a tomb underneath the church.

Over the centuries the church has withstood wars, looting, fires, earthquakes and other calamities. It also endured the Japanese occupation of Philippines during the World War II. It served as the concentration camp for prisoners and the hideout for Japanese soldiers with their hostages during the last days of the Battle of Manila.

Among the seven churches in the walled city, it was the San Agustin Church that remained standing after the liberation of Manila in 1945. Only its roof was destroyed by the bombardment of Intramuros by American-Filipino forces. Together with three other ancient churches in the country, it was designated as a UNESCO World Heritage Site as one of the “Baroque Churches of the Philippines” in 1993.



**San Agustin Church along with the other ancient churches in the country-Nuestra Señora de la Asuncion; Paoay Church; and Miag-ao Church.**



## San Agustin Museum

The monastery was originally used as the living quarters of the Augustinians, as well as serving as classrooms, refectory, vestry, library and infirmary.

It was destroyed by British forces in 1762, by the American soldiers in 1898 and during the Japanese and American liberation war in 1945. The monastery was converted into museum in 1973 and the Halls were restored. The family of Don Luis Araneta, a rich clan in Manila took over the ownership and management of the museum, and thus PAGREL Museum was born.

## Tropical Philippine Woods – An important component of San Agustin Church and Museum

The San Agustin Church has ornately carved wooden doors (*Vitex parviflora* Juss.) depict floras and the statues of St. Agustin, Sta. Monica and the Augustinian symbols. Indicating Chinese influence, four dogs stand at attention at the base of the building.



**Ornately carved wooden doors.**

The *trompe-l'oeil* ceiling painted by Italian artists Cesare Alberoni and Giovanni Debella in 1875 brightens the church interior (Figure 3). Hand-carved 17<sup>th</sup> century church pews made of molave (*Vitex parviflora* Juss.) are placed in the quire area. The Coro is made up of sixty-eight intricately carved kamagong (*Diospyros discolor* Willd.) choir stalls overlaid with narra (*Pterocarpus* spp.) inlays. The interior is also vested with a heavily gilded pulpit (with native flora and pineapple as its motifs), and a very ornate altar.



**Trompe-l'oeil ceiling**



**Ornate altar**



**Heavily gilded pulpit (with native flora and pineapple as its motifs)**



**Entrance**



**Bell**

***Entrance/Bell***

One gains entrance to the museum through the old poster's lodge where a 3,400 kilogram bell stands. It was taken down in 1927 from the belfry damaged by the earthquake of 1863.

***Sala Recibidor***

It houses the present PAGREL Museum of the San Agustin Church. It showcases the San Agustin Ivory Collection, wood art and antique collections, wooden statues and religious images of the late Don Luis MA. Araneta. Furthermore, a magnificent XVIII<sup>th</sup> century wooden retablo of the Intramuros Administration are neatly kept in this place.



## Corridors



The four corridors of the first floor of the museum exhibit oil paintings done by Filipino painters Enriquez, Fuster and others in the early XX<sup>th</sup> century. The paintings portray Saints and celebrities of the Augustinian Order.

## PAGREL Museum: Historical and Cultural Aspects of Wooden Cultural Heritages and Wood Materials

There was a view that identification of species used for these wood art collections would augment the appreciation of these religious statues by wood enthusiasts, students and the general public. In this regard, Ms. Elvira Araneta, daughter of Don Luis contacted the wood anatomist of the Forest Products Research and Development Institute (FPRDI). The principal author was a member of the team who conducted wood identification of these expensive woody art collections. The activity was carried out on 15-18 October 1985.



Wood identification for the general public is one among the manifold technical assistance activities rendered by the FPRDI. From the wood-using industries and from private sectors, many of those interested in the utilization of our timbers had come for our assistance. Their concern is not only on the identity of the specimens but also on other technical information among which are: (a) the distribution and supply of the species; (b) the substitutes either to a foreign species or to a given local species if the supply is limited; (c) various properties of the wood (physical, mechanical, working, seasoning, etc.); and (d) uses of the wood. These are some of the usual observations. The challenge regarding these problem areas is great, particularly of (a) and (b), so that the need to broaden our knowledge on these respects is essential to meet the desires of the end-users.

## **Wood Identification for the General Public**

One among the manifold technical assistance activities rendered by FPRDI aside from wood identification/identification of specimens, other technical information which include among others:

- Distribution and supply of the species;
- The substitutes either to a foreign species or local species if the supply is limited;
- Various properties of the wood physical, mechanical, working, seasoning, etc.; and
- Uses of the wood.

## **Characteristics of Wood (Details for Examination of Wooden Statues)**

Even without the aid of a hand lens or with just the naked eye, wood has easily recognizable structural features useful in species identification. Termed as gross features, they include the wood's physical properties (color, odor, taste, weight and luster or gloss) and those attributed to wood structure (grain, texture, rays, parenchyma, etc.).

The statues were brought outside the church and put (one at a time) in a place where there was sufficient light for easy scrutiny and identification. Inasmuch as the statues were painted or finished with varnishes, we relied principally on the structure of the wood. Equipped with a hand lens, we tried identifying the wood species where these wooden statues were carved. A problem we experienced was to locate the true cross section of the object. A cut was made in a portion that would not mark the appearance of the statue. In many instances the base part of the statues is curly grained, possibly obtained from a buttress, or some in advanced state of decomposition. In a few instances, some component parts have been replaced with different species. These antique religious wooden statues were collections from different parts of the Philippine archipelago by the Araneta family.

A total of 60 statues were identified. Some of these are the following: St. Joseph of Nazareth, Holy Water Font, the Holy Trinity, the Ascension, St. Michael the Archangel, vase-like Altar Finial, St. James the Greater or Santiago de Compostela, a standing angle, St. Paul, St. John the Baptist, St. Ferdinand, Sta. Rita de Cassia, Sorrowful Mother or Virgen de Dolorosa, St. John the Evangelist, St. Dominic, liturgical chair, Mexican crucifixes known as "Cristos de Caña", Jesus scourging at the Pillar, Jesus crowned with thorns, St. Agnes, St. Luke, carrozas (carriages), Corner altar dedicated to St. Thomas of Villanueva, St. Peter Martyr, Dominican St. Vicente, St. Rita, etc. These were all carved during the 18<sup>th</sup> century and collected from different parts of the Philippine archipelago (pls. refer to photos).



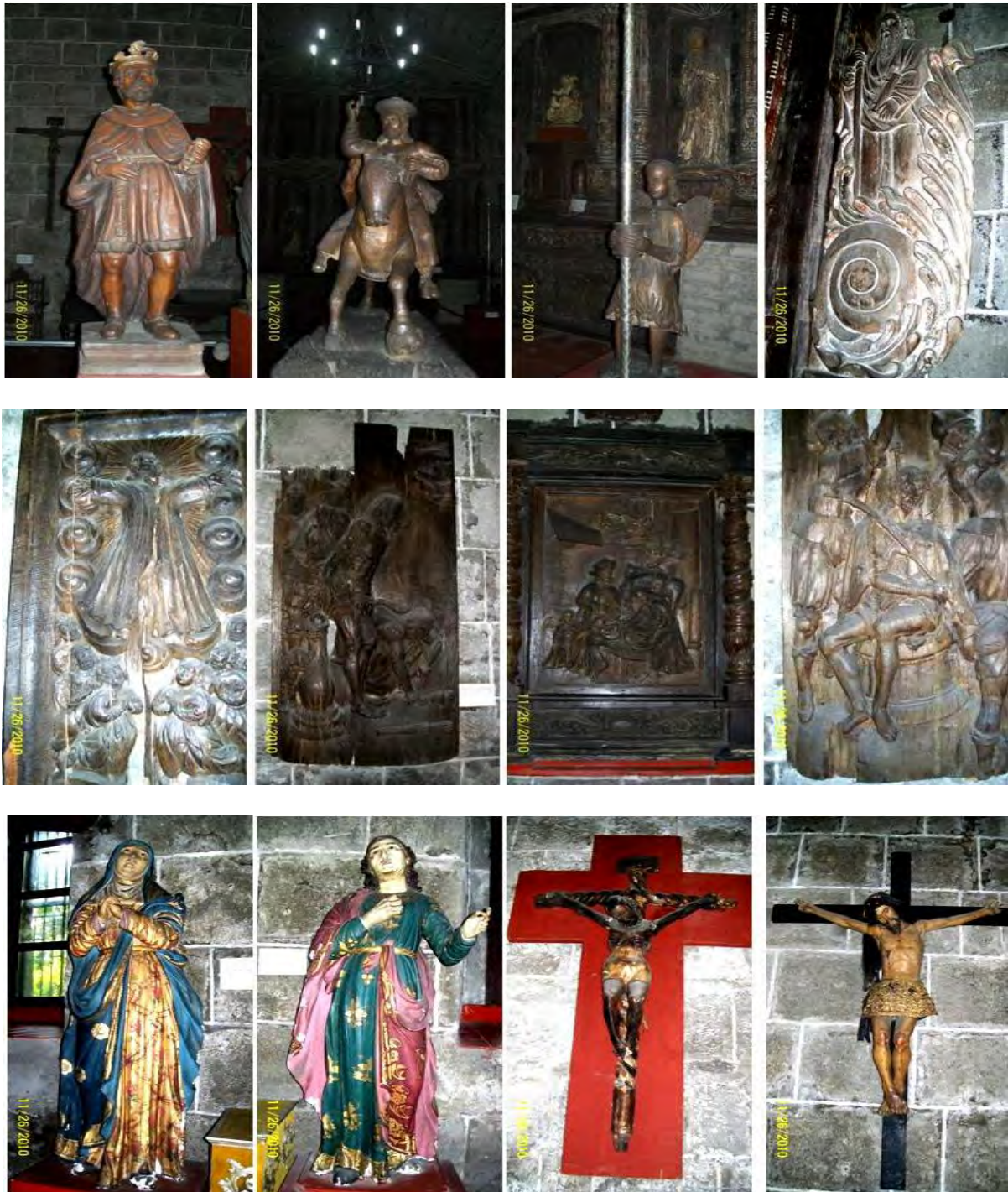





Among the principal species identified were those of molave (*Vitex parviflora* Juss.), batikuling (*Litsea leytensis* Merr.), narra (*Pterocarpus* spp.), makaasim (*Syzygium* spp.), santol (*Sandoricum koetjape* (Burm. f.) Merr.), maranggo (*Azadirachta excelsa* (Jack) Jacobs), kamatog (*Sympetalandra densiflora* (Elmer) v. Steen.), batitinan (*Lagerstroemia pyriformis* Koehne forma *batitinan* (Vidal) Furt. & Sris.), dungon (*Heritiera sylvatica* Vidal), acacia (*Samanea saman* (Jacq.) Merr.), and a miscellaneous species, malappingan (*Trichadenia philippinensis* Merr.).

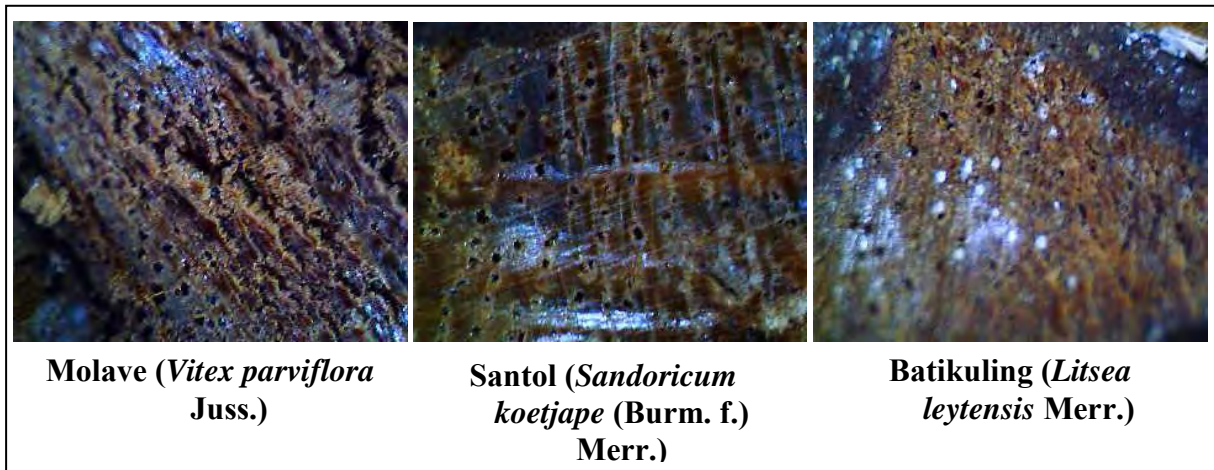

**Macro/microscopic characteristics of some wood species identified (Magnification 7X).**

## CONCLUDING REMARKS

PAGREL Museum in the San Agustin Church with expensive wood art collections is indeed a great treasure of Philippine arts and culture. Correct identification of these religious statues and images has added to their appreciation especially among wood enthusiasts and scientists. Further, antiques and woodcrafts that made the San Agustin Church, viz., the ornately carved, wooden doors, church pews, coro and ceilings, altar, tabernacle and certainly the wooden statues has truly made the church historical and cultural aspects of wooden cultural heritages, thus, the title of a UNESCO World Cultural Heritage.

## ACKNOWLEDGMENTS

The authors wish to extend their heartfelt gratitude to the family of Don Luis Araneta, owner of PAGREL Museum for their cooperation and unselfish attitude to have allowed them to take photos of available wood art collections, e.g., wooden saints and other religious images deposited at San Agustin Church in Intramuros, Manila.

## REFERENCES

Ella, A. B., J. M. Meniado, R. P. Escobin, et. al. 2009. Anatomical Identification Handbook of Philippine Dipterocarps. FPRDI Library. FPRDI, College, Laguna. 116 pp.

Meniado, J. A., W. M. America and B. C. de Vela. 1977. Observations and Related Problems in Wood Identification – Some Suggestions. Technical Note for Publication. FPRDI Library, FPRDI, College, Laguna. 4 pp.

Meniado, J. A., B. C. de Vela and A. B. Ella. 1985. Field Trip Report on the Identification of Wooden Statues at San Agustin Church in Intramuros, Manila. 15-18 October 1985.

Nikon D40 (KOOL NE Meetings, April 2008). Retrieved September 22, 2010, from <http://www.flicker.com/photos/bigberto/2592121796>.

Wikipedia 2010. San Agustin Church. Retrieved 22 September 2010 from [http://wikipedia.org/wiki/San\\_Agustin\\_Church/\\_Manila](http://wikipedia.org/wiki/San_Agustin_Church/_Manila).

WikiPilipinas 2010. San Agustin Church. Retrieved 22 September 2010, from [http://en.wikipilipinas.org/index.php?title=San\\_Agustin\\_Church](http://en.wikipilipinas.org/index.php?title=San_Agustin_Church).

# Wood Based Industry Development in Bhutan

Ugyen Tenzin<sup>20</sup>

## Abstract

*Bhutan's total land area is 38,394 square kilometers with forest coverage of 72.5%. Though rich in forest resources, the wood-based industry is facing acute shortage of timber supplies. Of the total registered wood-based firms, numbering 151, only 68 (45%) are fully operational. Recently, most of the saw mills and furniture houses were shut down as they could not get timber as per their requirement.*

*Most saw mills use old technology, in some cases up to forty years old, and as a result of which the recovery rate of sawn timber is very low, approximately 70% on an average. With rapid development taking place in Bhutan, the demand for timber from the construction sector is increasing every year giving huge burden to our forest resources.*

*If all the 68 fully operational sawmills operate at their full installed capacity, the timber requirement is 500 cft per day, which is far higher than the Natural Resources Development Corporation Limited's (NRDCL's) supply capacity. Considering the Government's planned activities for the next five years, the total demand for timber stands at 9.95 m cft per annum including rural supply of 6 m cft. The NRDCL & Department of Forest and Park Services' (DoFPS's) supply capacity is only 8.1 m cft per annum including rural supply. This leaves the supply gap of approximately 1.85 m cft of timber per annum for the next five years.*

*Hence, it is high time that the wood-based industries upgrade their wood-processing technology to increase yields by reducing waste and making better economic use of the limited resources. It is also time that the wood-based industries invest in technologies to make use of the wastes generated by them to produce other secondary value added products.*

*There are varieties of technology choices available in the market such as Woodmizer (US), Lucas (Australia), JAI Sawing Machines (India) and Sawing machines from China. Most of these new machines have higher recovery rate of about 80% and have several other advantages in terms of power consumption, less man-power requirement, better-cut quality, environmental-friendly operations and less waste generation.*

*It is observed from the study that the saw millers are willing to invest in modern sawing technology if the supply of timber is assured by the DoFPS and NRDCL in order to sustain their business. It is also expected that the government provide them assistance in terms of providing finance with subsidized interest rate on loans availed from the financial institutions. Other assistance expected is to provide tax-holiday for at least ten years.*

---

<sup>20</sup> Forest Resources Utilization Section, Department of Forests and Park Services, BHUTAN  
(utenzin\_2000@yahoo.com)

# Beauveria Bassiana, a Potential Mycopathogen for Management of Helopeltis Antonii Infesting Woody Trees

Ganga Visalaskhy<sup>21</sup> and Mani M

## Abstract

*Agro-forestry is found to be the most desirable strategy for maintaining social, economic and ecological sustainability in India. Insect pests are the most important group of organisms causing injury to plants in agro forestry systems. Helopeltis anotonii commonly known as the tea mosquito bug has a wide host range of 17 plant species representing 13 families in India. It is considered as a serious pest of neem, allspice, apples, black peppers, annatto, camphire (Lawsonia Alba), cinchona, grapevine, guavas, Moringa oleifera, jamboes or rose apples (Eugenia jambos), mangoes, Eucalyptus sp. cotton, mahogany, and drum stick. Nymphs and adults of H. anotonii mostly attack younger and softer parts of the plant, such as leaves, petioles, shoots, buds, inflorescences. They feed by sucking those plant parts and while they are sucking the plant fluid, they pump a secretion which contains a highly toxic substance. Feeding on tender leaves by young nymphs causes necrotic lesions. Meanwhile, feeding on inflorescences causes drying of the flowers and feeding on a growing tip or bud (primordial) can kill the bud. Seedlings can also become severely stunted and sometimes die from Helpless attack.*

*Many pests suffer from natural epizootics and therefore systematic research on insect pathogen holds great promise in forest insect pest management practices as it facilitates maintenance of the bio-diversity of forest fauna and flora leading to sustainability and value addition of wood and its products. An entomo-pathogen B.bassiana isolated from H. anotonii by Indian Institute of Horticultural Research, Bangalore, India recorded significant reduction in pest population under field conditions on Guava, a tree species of agro forestry. Based on the present results it could be inferred that H. anotonii could be controlled by insect pathogen B. bassiana leading to sustainability and value addition of woody trees.*

---

<sup>21</sup> Senior Scientist, Indian Institute of Horticultural research (IIHR), Division of Entomology and Nematology, Bangalore, INDIA (gangavpn@gmail.com, gangesv@iihr.ernet.in)

## 1. INTRODUCTION

In this era of global warming, fast degradation of land productivity and other environmental hazards, forestry is increasingly relevant with respect to natural resources and socio-economic sustainability. Agro-forestry is found to be the most desirable strategy for maintaining social, economic and ecological sustainability in India. However, Insect pests are the most important group of organisms causing injury to plants in agro forestry systems. Therefore, the management of insect pests in these systems is crucial to sustained production, and even farmers have recognized this as a priority issue for agro forestry research. Among the various insect pests of forestry, the tea mosquito bug *Helopeltis antonii* is reported to be a major pest of woody trees in spite of several insecticidal ingredients, such as the tetranortriterpenoid azadirachtin, the neem tree, *Azadirachta indica*, is attacked by a large number of insect pests, of which the tea mosquito bug *Helopeltis antonii* is a major example, causing about 15% damage to seedling (Ahmed, 1984, 1998, 2008, Onkarappa and Kumar 1997). Devasahayam and Nair (1986) recorded that *H. antonii* has a wide host range of 17 plant species representing 13 families. Among the major economic crops attacked by *H. antonii* are cacao (*Theobroma cacao*), tea (*Camellia sinensis*), cashew (*Anacardium occidentale*). Other reported feeding hosts are allspice, annatto, apples, black peppers, campfire (*Lawsonia alba*), cinchona, grapevine, guavas, *Moringa oleifera*, jamboes or rose apples (*Eugenia jambos*), mangoes, *Eucalyptus* sp. cotton, mahogany, red gram, and drum stick

Nymphs and adults of *H. antonii* attack younger and softer parts of the plant, such as leaves, petioles, shoots, buds, inflorescences and fruits. They feed by sucking those plant parts and while they are sucking the plant fluid, inject toxic saliva. The general symptoms are the discolorations and presence of necrotic areas or lesions around the entry point of labial stylet of the insect into plant tissue. These lesions darken with age as the tissue around the puncture dies. Feeding on tender leaves by young nymphs causes necrotic lesions meanwhile feeding on inflorescences causes drying of the flowers and feeding on a growing tip or bud (primordial) kills the bud. Lesions on fruit appear as brownish or black and die on the tree and may drop off. Older nuts are not killed but reduced in their size and circular lesion spots result in the reduction of quality. Seedlings can also become severely stunted and sometimes die from *Helopeltis* attack (Swaine 1959; Ohler 1979). The damage by the insect is dependent on the tree species, time of attack and varies from 20- 70 per cent across tree species of neem to guava.

Many pests suffer from natural epizootics and therefore systematic research on insect pathogen holds great promise in forest insect pest management practices as it facilitates maintenance of the bio-diversity of forest fauna and flora leading to sustainability and value addition of wood and its products (Ahmed, 1991).

This paper reports on the efficacy of an insect pathogen *Beauveria bassiana* against *H. antonii*, a pest of woody trees of forestry in India.

## 2. MATERIALS AND METHODS

### a. Source of the pathogen *B. bassiana*

The Indian institute of Horticultural Research, Bangalore has isolated a myco-pathogen from an adult insect that was identified as *Beauveria bassiana* (Ganga Visalakshy and Mani, 2010). The pathogen was pure white and had covered most of the insect body except the head and legs (Fig. 1). The pathogen was isolated to pure culture and initially mass cultured on potato dextrose agar.

### **b. Mass multiplication of entomopathogen *B.bassiana*.**

To prepare solid mass production media conidia from two weeks old culture plate was collected in sterile water to make the concentration of  $2 \times 10^6$ /ml. 200 gram of sorghum was weighed and taken in 500 ml conical flask to which 150 ml of clean tap water was added, plugged with non absorbent cotton and autoclaved twice at 121°C and 15psi for 15 min. to avoid contamination. After autoclaving flasks were allowed to cool down and clumps inside the flasks separated by shaking flasks vigorously, then each flask was inoculated with 1 ml of *B.bassiana* spores having  $2 \times 10^6$  concentration/ml. Then all the flasks were incubated at  $25 \pm 10$  c for 30 days in normal day and night photoperiod for the mycelia growth and sporulation. After complete growth, they were tested for number of spores per gram using haemocytometer and number of viable spores per gram using CFU. For the experiment 10 g of the above solid media is dissolved in 1 L water to make the recommended dosage of  $1 \times 10^9$  spores/ml.

### **c. Efficacy against *H. antonii* under field conditions.**

The efficacy of *B. bassiana* against *H. antonii* was carried out under field conditions in Heassrghatta on guava. The experiment included three treatments, *B. bassiana* @  $1 \times 10^9$  spores/ml, chemical insecticide Lambda-cyhalothrin @0.5ml/L and unsprayed control. Each treatment had four trees, where each tree is considered as a replicate. Two sprays were given at onset of fruit set at 15 days interval. Observations on the effect of *B. bassiana* on *H. antonii* were made once the fruits are hardened (stage not preferred by the insect). For recording data, four branches were randomly selected from each side of the tree and number of fruits damaged by the pest and healthy fruits on these branches were separately recorded. The observations were pooled as number damaged per tree later converted to percentage.

## **3. RESULTS**

### **Efficacy against *H. antonii* under field conditions.**

Results indicated significant reduction in fruit damage in the treatments as compared to control trees. The IIHR isolate *B. bassiana* recorded 4.87 % fruit damage as compared to 62.2% in untreated check. Lambda – cyhalothrin that recorded lowest fruit damage of 2.29%. *B. bassiana* is reported as an effective biological control agent of tea mosquito bug, *H. theivora* Waterhouse (Hemiptera: Miridae) in Assam (Hazarika et al., 2009).

It is concluded that IIHR isolate of *B.bassiana* is a promising biological control of *H. antonii* could be recommended as an alternative to application of chemicals to manage in woody trees of India and many other countries of the world. It has been recommended Many pests suffer from natural epizootics and therefore systematic research on insect pathogen holds great promise in forest insect pest management (Ahmed,1991). Management of *H. antonii* by using this insect pathogen holds great promise in forestry as it leads to bio-diversity conservation in forest ecosystem thereby resulting in sustainability and value addition of woody trees and its products.

## **4. REFERENCES**

Ahmed, 1991. Scope of biological control in forest pest management in arid zone. In Proc. Afforestation of Arid lands. IAXFR Jodhpur.

Ahmed, S.I., Kumar, S. and Mathur G. 1999). Bioecology and management of *Helopeltis Antonii* Signoret (Heteroptera: Miridae), a serious pest of neem trees in Rajasthan and Gujarat. *Annals of Entomology* , 17(1):264-284

Ahmed1998. *H. antonii* Signoret ( Mirida) a potential pest damaging neem trees in Tamil Nadu with a special note on its control presented in 75t Indian soc. Congress, Pune.

Ahmed, S.J. 2008 Pest fo neem and their management in Arid and semi arid region. In *Forest entomology* eds. Jha, .L.K. Sen Sharma.P.K. publ S. B Nanagia APH publishing corporation, New Delhi.

Ganga Visalakshy. P.N. and M. Mani. M. 2011. Record of *Beauveria bassiana* on tea mosquito bug, *Helopeltis antonii* Signoret in guava ecosystem *Journal of Biological Control*, 25 (2): 150–151, 2011

Hazarika, L. K., Budhinda, M. B. and Hazarika. N. 2009. Insectpests of tea and their management. *Annual Review of Entomology*, 54: 267–284.

# **Bacillus Subtilis B2, a Potential Bioprotectant for the Control of Sapstain on Rubber Wood**

**Maria Florence E J<sup>22</sup> and Sajitha K L<sup>23</sup>**

## **Abstract**

*Rubber wood after the extraction of latex is an alternative species for the conventional timbers in the wood based industries in Kerala. But its utilization is restricted due to the bluish back fungal staining caused by Botryodiplodia theobromae. Due to environmental and health hazards caused by chemical preservatives, biological control strategy for preventing the sapstain using antagonistic microorganisms is adopted. Among the several microorganisms screened, the bacterium Bacillus subtilis B2 was identified as a potential bioprotectant for sapstain. One of the antifungal antibiotics, Iturin A produced by the bacterium was identified using HPLC. B. subtilis B2 was found to be effective in controlling the sapstain in the field.*

**Key words:** *Bacillus subtilis*, *Botryodiplodia theobromae*, sapstain, antagonism, rubber wood

---

<sup>22</sup> Forest Pathology Department, Kerala Forest Research Institute, Peechi, Thrissur, Kerala, 680 653, INDIA (flory@kfri.org)

<sup>23</sup> Senior Research Fellow, Dept. of Forest Pathology



## 1. INTRODUCTION

Natural forest resources are being depleted day by day. The growing demand for conventional timbers can be met to some extent by utilizing rubber wood as an alternative. Fungi cause different types of damages such as surface growth (mould), sapstain, soft rot and decay (Subramanian, 1983). The hot and humid climate of Kerala is favourable for the growth of sapstain fungi and moulds on soft wood species. Among the different sapstain fungi, *Botryodiplodia theobromae* Pat., an important ubiquitous facultative wound pathogen which is widely distributed in tropics and sub tropics causes bluish-black discolouration on rubber wood (Florence et al., 1999). *B. theobromae*, the dominant stain fungus does not reduce the wood strength much (Blanchette et al., 1992) but will affect the economic importance of the timber.

Protection of wood and wood products from fungal deterioration is achieved mainly through chemical wood preservatives. But health hazards and environmental pollution due to various preservatives necessitates seeking alternative methods to prevent fungal infection. Biological control, based on microorganisms to suppress fungal infection offers a potent substitute to synthetic chemicals. The use of bacteria as a biocontrol agent is investigated highly because the biochemical, genetic analysis and mass production of bacteria are more precise than fungi. Several microbes such as *Agrobacterium*, *Pseudomonas*, *Bacillus*, *Alcaligenes*, *Streptomyces* etc. were reported as bacterial biocontrol agents (Liang et al., 1982; Weller, 1988; Gutterson, 1990; Dowling and O'Gara, 1994). The bacterial antagonists assume their antagonistic effects mainly by the production of antifungal antibiotics and many of these antibiotics have been characterized and identified as peptide antibiotics (Katz and Demain, 1977). Among them, iturin A has very less toxicity and allergic effect on animals (Quentin et al., 1982) and stands as a candidate for environmentally safe biological pesticide (Phae et al., 1992).

The objective of the study was to isolate, screen and identify possible microorganisms antagonistic to the stain fungus *Botryodiplodia theobromae* and to identify the antagonistic principle responsible for the fungal inhibition.

## 2. MATERIALS AND METHODS

### 2.1. Isolation of antagonistic microorganisms, detection of antagonistic activity and identification of the effective bacterium

Microorganisms were isolated for antagonistic ability from the soil, compost and wood. Samples were serially diluted and isolated using Starch Casein Agar for actinomycetes, Soil Extract Agar for bacteria and Rose Bengal Agar for fungi. From the isolates, the microorganisms showing antagonism were screened on Potato Dextrose Agar using dual culture technique (Johnson and Curl, 1972). In one method the selected pure cultures were streaked on the periphery of the petri dish and allowed to grow. After one week, a 5 mm dia mycelial disc taken from actively growing culture of test fungus was inoculated on the opposite side of the test microbe. In the second method, pure culture was grown at three equidistant positions on the PDA plate and the fungus was inoculated at the centre. After incubation for 7 days at  $28 \pm 2^\circ\text{C}$ , the radial growth of *B. theobromae* and the zone of inhibition were observed. Three replications were maintained for treatment and control. From the screened cultures, the very efficient bacterium B2 was selected against *B. theobromae*. Gram staining and biochemical tests were done for identifying the bacterium.

## 2.2. Amplification of 16S rRNA

Genomic DNA preparation of B2 was done adopting the protocol of Ausubel et al. (1994). To characterize the bacterial strain, the small ribosomal RNA unit was amplified by PCR using the conserved primers (forward 8F-F 5' AGTTGATCCTGGCTCAG 3' and Reverse 1492 – R 5' ACCTTGTTACGACTT 3') (Sacchi et al., 2002). The PCR reaction mix (25µl) was made by mixing the following components. 1µl of template DNA, 0.125µl of each primer, 0.5µl of 10mM dNTPs, 5µl of 5xHF buffer, 1.25µl Phusion DNA polymerase and 17µl of sterile distilled water. Amplification was carried out as follows: A preliminary denaturation step was done at 98°C for 30 S, followed by 35 cycles at 98°C (denaturation), 20 S at 40.4°C (annealing) 25 S at 72°C (extension) after 35 cycles, a final extension of 10 minutes at 72°C was done. The PCR product was checked by electrophoresis and was sequenced at MWG BIOTECH, Bangalore for species identification.

## 2.3. Production, extraction and identification of antifungal antibiotics

The B2 strain was cultured in 100 ml chemically defined medium (2% glucose, 3% peptone, 0.5% yeast extract, 0.1% KH<sub>2</sub>PO<sub>4</sub>, 0.05% MgSO<sub>4</sub>, 0.01% CaCO<sub>3</sub>, 0.01% NaCl) at 37± 2°C, 100 rpm for 2 days. After incubation, the culture was centrifuged at 12000 rpm for 15 minutes at 4°C. To check the antifungal activity of the bacterial extract, 1 ml of the filter sterilized bacterial filtrate was poured to a well bored in the PDA medium. An 8 mm dia mycelial disc taken from the edge of an actively growing culture of *B. theobromae* was inoculated at the opposite side. The plate was incubated at 28 ± 2°C for one week for observing the antagonism. The cell free culture broth obtained from the chemically defined medium was acidified by HCl to pH 2. The precipitation was collected by centrifugation and the solid was air dried overnight. It was then extracted with ether for 6 h in a soxhlet extractor to remove nonpolar biologically inactive impurities. The remaining solid was dissolved in methanol and the solution was chromatographed on a reversed-phase absorbent C-18 column.

## 2.4. HPLC Analysis

An authentic sample of Iturin A from Sigma Aldrich, US and methanol, water and acetonitrile of HPLC grade from Merck were obtained for HPLC analysis. Sample was analyzed by reversed-phase C-18 HPLC. Chromatography was performed on a Shimadzu model SCL-10AVP controller equipped with a Shimadzu model SPD-M 10AVP photo diode array detector. The Column used was Shimadzu model CTO-10 ASVP, Luna 5u C18 (2) 100A, 250 x 4.6 mm. The mobile phase was 65% water and 35% acetonitrile. The flow rate was 0.75 mL/min. The range of detection wavelength was set from 190 to 800 nm.

## 2.5. Wood block tests

Fresh rubber wood blocks (7 x 5 x 1cm), steam sterilized at 15 lb/in<sup>2</sup> for 20 minutes were dipped in B2 bacterial culture (10<sup>7</sup> cfu/ml) and its filtrate, grown in chemically defined medium. The treated blocks were inoculated with *B. theobromae* and kept in sterile Petri dish with a moist filter paper. Wood blocks dipped in sterile water and inoculated with the test fungus were kept as control and incubated at room temperature. Results were observed after one month.

The field-testing was done during the month of July (southwest monsoon) and November (northeast monsoon) at Evershine Packing Industries, Ollur, Thrissur. Fresh rubber wood planks of 500 x 100 x 15 mm thickness were used for testing. After removing the sawdust, wood planks were dipped in

the bacterial culture ( $10^7$  cfu/ml) for 10 minutes. The excess solution from the wood planks was drained by keeping them in slanting position and stacked closely and openly. For both seasons, the same pattern of stacking was followed.

**Close stacking:** In a single stack, there were a total of 30 planks. For close stacking 3 replicate stacks were maintained for both treatment and control. In each stack, one row consisted of 5 planks and in each stack there were six rows.

**Open stacking:** Open stacking was made in such a way that a space of 50 mm was left in between planks. All the planks were arranged in criss-cross pattern. The control planks were also stacked in the same manner. Observations for the growth of fungi in both the stacks were recorded after one month. All the planks were arranged on the floor under a shed. At the end of the treatment period, the planks were observed for fungal growth on the surface and assessed visually using the rating index given in Table 1. The planks were planed for observing the internal stain.

**Table 1. Rating index for mould/stain/decay fungi**

Rating	Mould/stain & decay
0	No fungal growth
1	<10%
2	10-25%
3	26-50%
4	51-75%
5	76-100%

### 3. RESULTS

#### 3.1. Isolation of antagonistic microorganisms, detection of antagonistic activity and identification of the bacterium



**Fig. 1. Bacteria at three portions**

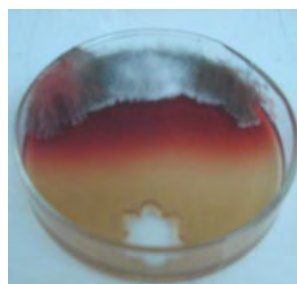

**Fig. 2. Zone of inhibition of *B. theobromae* developed by the *B. subtilis* B2 culture filtrate**

The microorganisms isolated for screening against *B. theobromae* from various source materials include: 30 actinomycetes, 10 bacteria and 16 fungi from compost, 14 actinomycetes, 5 bacteria and 7 fungi from rubber wood and 9 actinomycetes, 4 fungi and 9 bacteria from soil. Among the antagonistic microbes, one highly effective bacterium, B2 isolated from the compost was selected. The bacterium B2 showed strong antagonism in the dual culture towards the fungus (Fig. 1). The culture filtrate of the bacterium also inhibited *B. theobromae* (Fig. 2).

### 3.2. Identification of the bacterial strain (B2)

From the gram staining and biochemical tests, the bacterium B2 was identified as *Bacillus* species. In PCR amplification the 16S rRNA of B2 genome was amplified to around 1400 bp using the specific forward and reverse primers for *Bacillus* genus. When the sequenced 16S rRNA gene was analyzed in BLAST nucleotide analyzer, it showed 99% similarity to *Bacillus subtilis* and thus the isolated antagonist B2 was confirmed as *Bacillus subtilis* B2 and it is deposited in the gene bank with accession no FJ445405.

### 3.3. Production, extraction and identification of antifungal antibiotics

The antibiotics produced by *Bacillus subtilis* were isolated and extracted. One of the antibiotics extracted was identified as Iturin A using HPLC with an authentic Iturin A standard (Figs. 3a & b). The retention time of the standard Iturin A was 4.878 and the maximum absorbance was noticed at 254 nm. In the sample, at the same retention time, 4.837, a peak was observed and the UV spectra of both peaks were similar and proved to be the same compound. The extra peaks observed in the chromatogram represented other antibiotics.

**Fig. 3 a. Chromatogram of iturin A standard and sample**

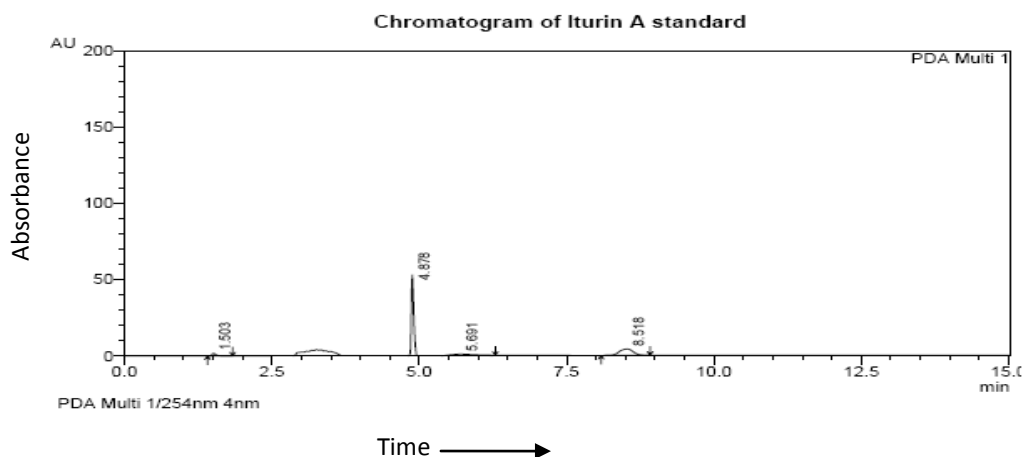

**Fig. 3b Chromatogram of Bacillus subtilis Antibiotics**

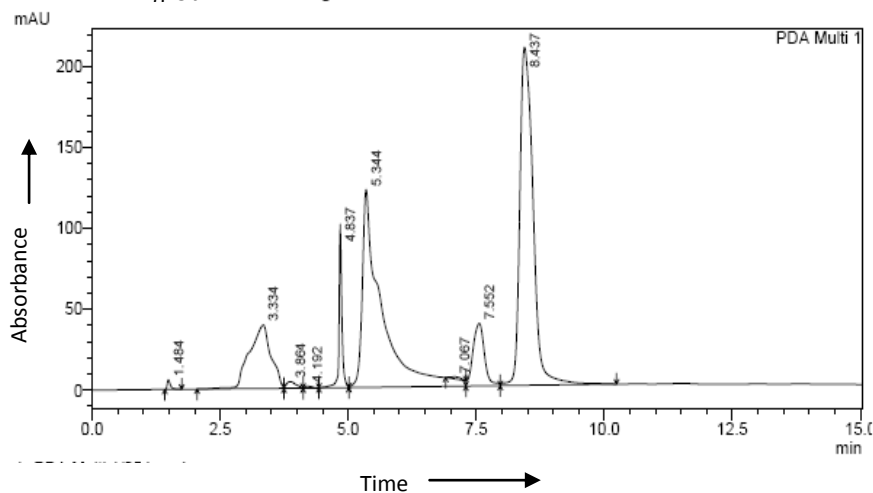

**3.4. Wood block tests:** No growth of the *B. theobromae* was observed on the wood blocks dipped in *B. subtilis* B2 culture in the laboratory (Fig. 4). In the wood blocks dipped in culture filtrate, the growth of *B. theobromae* was very much restricted when compared to control blocks (Fig. 5).

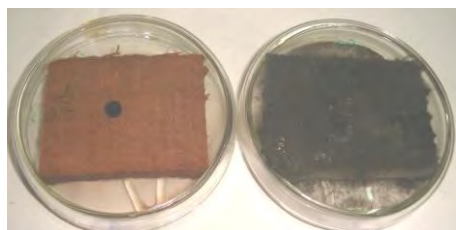

Treated Control

**Fig. 4.** Wood blocks treated with *B. subtilis* B2

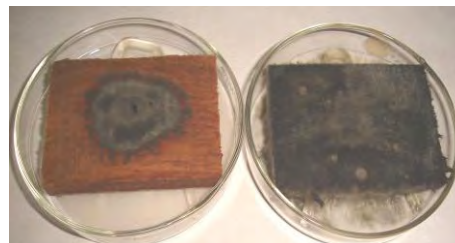

Treated Control

**Fig. 5.** Wood blocks treated with culture filtrate of *B. subtilis* B2

Close stacking				Open stacking			
<i>Bacillus subtilis</i> B2 treated		Control		<i>Bacillus subtilis</i> B2 treated		Control	
Surface growth % (Rating)	Inner staining % (Rating)	Surface growth % (Rating)	Inner staining % (Rating)	Surface growth % (Rating)	Inner staining % (Rating)	Surface growth % (Rating)	Inner staining % (Rating)
8 (1)	1.7 (1)	57 (4)	24.7 (2)	2 (1)	0	15 (2)	9 (1)
9 (1)	2.5 (1)	55.3 (4)	24 (2)	2.5 (1)	0	12.7 (2)	7.7 (1)
9.6 (1)	2.5 (1)	51.5 (4)	22.5 (2)	1.5 (1)	0	13.5 (2)	8 (1)

**Table 2.** Rating of the open and close-stacked planks treated with bacterial culture in north east monsoon

In the field, open stacking inhibited the fungal infection during northeast monsoon than the close stacking (Fig. 6, Table 2). When compared to northeast monsoon, the percentage of sapstain was less in bacterial treated planks than the planks treated in southwest monsoon.



Control                      *Bacillus subtilis* B2  
treated

**Fig. 6. Surface growth of *B. theobromae* on the control planks**

#### 4. DISCUSSION

In the present study the bacterium *B. subtilis* B2 has been proved as a biocontrol agent against sapstain fungus, *B. theobromae* on rubber wood both in the laboratory and field. Several workers have proved the effectiveness of *B. subtilis* as a biocontrol agent against stain and surface fungi (Feio et al., 2004; Bernier et al., 1986; Seifert et al., 1987).

The mechanisms of biological control are generally classified as competition, parasitism and antibiosis. Inhibition may be due to the production of antifungal metabolites (Podile and Prakash, 1996) or due to nutrient competition (Bernier et al., 1986). Since, in vitro assays showed that the culture filtrate had antifungal capability; the inhibition of fungal growth may be due to the production of antifungal metabolites. Evidences suggest that the principal mechanism of this antifungal action involves the production of antibiotics (Fravel, 1988).

*Bacillus* species are well known producers of antibiotics (Gueldner, et al., 1988; Rossall, 1991; Gong, et al., 2006). A wide range of antibiotics are produced by *Bacillus* sp. such as Iturin A, Mycosubtilin, Fengycin and Bacillomycin by *B. subtilis* (Rossall, 1991), Bacitracin by *B. licheniformis*, and Polymixin by *B. polymyxa* (Katz and Demain, 1977). Analytical reports of the *Bacillus subtilis* B2 showed that the main antifungal compounds were the antibiotics and one among them was Iturin A. The major role of Iturin A as antifungal peptides in biocontrol was studied by Gueldner et al., (1988) and Gong et al., (2006). Iturins are a group of similar cyclic lipopeptides with high antifungal activity, which can modify the membrane permeability and lipid composition and inhibit the mycelium growth and sporulation of fungi (Latoud et al., 1987). Various studies have been carried out on the isolations and antifungal activities of the iturin group antibiotics (Peypoux et al., 1985; Besson and Michel, 1986; Eshita et al; 1995). But the effect of antifungal antibiotics on sapstain fungus *B. theobromae* was studied for the first time in this trial. Iturin A, along with other antibiotics proved to play a major role in inhibiting the growth of sapstain fungus, *B. theobromae*.

In the field the planks treated in northeast monsoon season was giving good protection against sapstain than the planks treated in southwest monsoon. The reason for the low percentage of control in south west monsoon season may be the presence of high amount of fungal growth due to the congenial atmospheric condition such as high humidity and high moisture content. In Kerala the maximum amount of rain is recorded during southwest monsoon.

In order to get maximum protection from fungal growth, the quantity of antibiotics produced in the bacterial culture must be increased. A further study is needed for mass production of *B. subtilis* B2 and enhanced production of antifungal antibiotics.

## 5. REFERENCES

Ausubel, MF, Brent, R, Kingston, RE, Moore, DD, Seidman, JG, Smith, JA, and Struhl, K, 1994, Preparation of genomic DNA from bacteria, Current protocols in molecular biology, Vol. 1, John Wiley and Sons. Inc, 2.4.1 – 2.4.2.

Besson, F, and Michel, G, 1986, Isolation and characterization of new iturins: iturin D and iturin E. The Journal of Antibiotics, XL (4), pp 437-442.

Bernier, R, Desrochers, M, and Jurasek, L, 1986, Antagonistic effect between *Bacillus subtilis* and wood staining fungi. Journal of the Institute of Wood Science, 10 (5), pp 214-216.

Blanchette, RA, Farrell, RL, and Burnes, TA, 1992, Biological control of pitch in pulp and paper production by *Ophiostoma piliferum*. TAPPI Journal, 75, pp 102-106.

Dowling, DN, and O’Gara, F, 1994, Metabolites of *Pseudomonas* involved in the biocontrol of plant disease. Trends Biotechnology, 12, pp 133-141.

Eshita, SM, Roberto, NH, Beale, JM, Mamiya, BM, and Workman, RF, 1995, Bacillomycin L, a new antibiotic of the iturin group: Isolations, structures and antifungal activities of the congeners. The Journal of Antibiotics, 48(11), pp 1240-1247.

Feio, SS, Barbosa, A, Carbita, M, Nunes, L, Esteves, A, Roserio, JC and Curto, MJM, 2004, Antifungal activity of *Bacillus subtilis* 355 against wood-surface contaminant fungi. Journal of Indian Microbiology and Biotechnology, 31, pp 199-203.

Florence, EJM, Sharma, JK, and Gnanaharan, R, 1999, Changes in the strength properties of sapstained rubber wood. Material und Organismen, 32(4), pp 315-319.

Fravel, DR, 1988, Role of antibiosis in the biocontrol of diseases. Annual Review of Phytopathology, 26, pp 75-91.

Gong, M, Wang, JD, Zhang, J, Yang, H, Lu, XF, Pei, Y and Cheng, JQ, 2006, Study of the antifungal ability of *Bacillus subtilis* strain PY-1 in vitro and identification of its antifungal substance (Iturin A). Acta Biochimica et Biophysica Sinica, 38(4), pp 233-240.

Gueldner, RC, Reilly, CC, Pusey, PL, Costello, CE, Arrendale, RF, Cox, RH, Himmelsbach, DS, Crumley, FG and Cutler, HG, 1988, Isolation and identification of Iturins as antifungal peptides in biological control of peach brown rot with *Bacillus subtilis*. Journal of Agriculture and Food Chemistry, 36, pp 366-370.

Gutterson, N, 1990, Microbial fungicides: recent approaches to elucidating mechanisms. Critical Reviews in Biotechnology, 10, pp 69-91.

Johnson, LF, and Curl, EA, 1972, Testing for antibiotic activity, Methods for research on the ecology of soil-borne plant pathogens, Burgess Publishing Company, Minneapolis, pp 153-155.

Katz, E, and Demain, AL, 1977, The peptide antibiotics of bacillus : chemistry, biogenesis and possible functions. *Bacteriological review*, 41, pp 449 – 474.

Latoud, C, Peypoux, F, and Michel, G, 1987, Action of iturin A, an antifungal antibiotic from *Bacillus subtilis*, on yeast *Saccharomyces cerevisiae*: Modifications of membrane permeability and lipid composition. *The Journal of Antibiotics (Tokyo)*, 40, pp 1588-1595.

Liang, LN, Sinclair, JL, Mallory, LM, Alexander, M, 1982, Fate in model ecosystems of microbial species of potential use in genetic engineering. *Applied Environmental and Microbiology*, 44, pp 708-714.

Peypoux, F, Marion, D, Maget-Dana, R, Ptak, M, Das, BC, and Michel, G, 1985, Structure of Bacillomycin F, a new peptidolipid antibiotic of the iturin group. *European Journal of Biochemistry*, 153, pp 335-340.

Phae, CG, Shoda, M, Nobuhiro, K, Nakano, M, and Ushiyama, K, 1992, Biological control of crown and root and bacterial wilt of tomato by bacillus subtilis NB22. *Annals of phytopathology Society*, 58, pp 329-339.

Podile, AR, and Prakash, AP, 1996, Lysis and biological control of *Aspergillus niger* by *Bacillus subtilis* AF 1. *Canadian Journal of Microbiology*, 42, pp 533-538.

Quentin, MJ, Besson, F, Peypoux, F, and Michel, G, 1982, Action of peptidolipidic antibiotics of the iturin group on erythrocytes. Effect of some lipids on hemolysis. *Biochimica Biophysica Acta*, 684, pp 207-211.

Rossall, S, 1991, Antibiotic derived from *Bacillus subtilis*. US Patent No: 5061495.

Sacchi, CT, Whitney, AM, Mayer, LW, Morey, R, Steigerwalt, A, Boras, A, Weyant, RS, Popvic, T, 2002, Sequencing of 16S rRNA gene: a rapid tool for identification of *Bacillus anthracis*. *Emerging Infectious Diseases*, 8, pp 1117-1123.

Seifert, KA, Hamilton, WE, Breuil, C, and Best, M, 1987, Evaluation of *Bacillus subtilis* C186 as a potential biological control of sapstain and mould on unseasoned lumber. *Canadian Journal of Microbiology*, 33, pp 1102-110

Subramanian, CV, 1983, *Hyphomycetes, Taxonomy and Biology*. Academic Press, London 502pp.

Weller, DM, 1988, Biological control of soil borne pathogens in the rhizosphere with bacteria. *Annual Review of Phytopathology*, 26, pp 379-407.



# Bio-Pallets from Waste Wood and Agriculture Residues: A Path to a Sustainable Future

Dr. Beena Patel<sup>24</sup>

## Abstract

*Abellon's core purpose is to increase energy access globally in a sustainable manner. Harnessing bioenergy via bio-pellets, Abellon strives to balance amongst food, fodder, fiber and fuel. While making a sustainable use of leftover organic residues, it develops the opportunities to "Go Green". It reduces GHG emissions & local pollutants, while avoiding any interference with existing agricultural practices and land use patterns.*

*Towards its sustainable energy generation efforts, Abellon is keen to position and harness the rich potential of bioenergy – a source of energy which is abundantly available in nature – through manufacturing and selling bio-pellets – made from leftover agricultural and wood residues.*

*Bio-pellets– Pellexo – provide a carbon-neutral, sustainable alternative to conventional fossil fuels, (mainly coal and lignite) used in the industries. It substantially lowers particulate emissions, while allowing remarkable consistency and burn efficiency. Pellexo is used at the industrial, community and retail sectors. At industrial level, it is used for utility requirement for industrial units having FBC boilers, Traveling grate boilers, Thermic fluid heaters, Hot air generators and for co-firing in large thermal power plants. At community level, it is can be used at community cooking stoves and large spaces such as malls, educational institutions, etc. At retail level, it is used at the pellet stoves in domestic / home heating and cooking applications.*

*Pellexo includes Environmental, Social and Economic Benefits. Pellexo has a calorific value of 4100 kcal/kg. Energy produced would be approx. 4.7683 kilowatt hour (kW·h)/kg. Coal and Lignite are replaced by Pellexo. One tone of Pellexo replaces 1.5 tonnes of lignite. One tonne of Coal replaced with Pellexo can reduce 1.7 tonnes of CO<sub>2</sub>. It reduces deforestation, local air, water or ground pollution, reduces indoor air pollution and improves waste management. Wealth generation from wood and agriculture residues results into economic growth of farmers, rural development through employment generation.*

**Key Words:** Agriculture residues, bioenergy, bio-pellets, environment, sustainable energy

---

<sup>24</sup> Head R & D, Abellon CleanEnergy Ltd, Sydney House, Premchand Nagar Road, Bodakdev, Ahmedabad-380054. INDIA. Tel: +91-79-66197777, Fax: +91-79-66309341 (beena.patel@abelloncleanenergy.com, www.abelloncleanenergy.com)

## 1. INTRODUCTION

The Abellon Group is committed to contribute towards nation building through its diverse business and social activities. Abellon operates businesses with a triple bottom line approach of achieving economic, social and environmental objectives. Through its presence in sectors such as clean energy, agriculture and genomics research, Abellon aims to create businesses that provide financial inclusion to the ‘bottom of the pyramid’, preserve the environment, even while generating a good economic return on capital (FIGURE-1).

**Figure 1: Abellon Group companies**



Abellon CleanEnergy aims at increasing energy access globally in a sustainable manner, through non-revenue generating agriculture residue collection platform called “poornakumbha” which mainly supports the bioenergy initiatives of Abellon in terms of uninterrupted biomass sourcing. Poornakumbha is a sustainable, community-development-centric approach added to Abellon's sustainable business model. It mainly supplies agriculture biomass for pellets manufacturing operations through “decentralized collection model”.

Towards its sustainable energy generation efforts, Abellon is keen to position and harness the rich potential of bioenergy – a source of energy which is abundantly available in nature – through manufacturing and selling bio-pellets – made from leftover agricultural residue. Our bio-pellets – Pellexo – provide a carbon-neutral, sustainable alternative to conventional fossil fuels, (mainly coal and lignite) used in the industries. It substantially lowers particulate emissions, while allowing remarkable consistency and burn efficiency.

On a larger term, Poornakumbha support Abellon's vision of achieving inclusive rural development. This vision is actualized through various initiatives in the rural community undertaken by Poornakumbha.

## 2. AIM AND OBJECTIVE

Abellon’s core purpose is to increase energy access globally in a sustainable manner. India, as an emerging country strives to meet the growth rate of Indian economy at about 8.6%. As a developing

nation, it is also working to meet Millennium Development Goals (MDGs) and following COP15, it has pledged to cut 20-25% emissions by 2020 from 2005 levels.

Harnessing bioenergy via bio-pellets, Abellon strives to balance amongst food, fodder, fiber and fuel. While making a sustainable use of leftover organic residues, it develops the opportunities to Go Green. It reduces GHG emissions & local pollutants, while avoiding any interference with existing agricultural practices and land use patterns.

Largely, it includes Poornakumbha to promote an inclusive, innovative and supportive growth model which also boosts the rural economy through generating significant income & employment opportunities to farmers.

### 3. “PELLEXO”-BIOPELLET PRODUCTION

The raw materials, agriculture residues and wood waste are directly sent to pre-processing units for reducing the size of feed material. The uniform raw material is conditioner with water if required to maintain humidity. The material transferred to pellet mills through rotary feeder. The Pellet mill is main processing unit wherein two rotors are stable & Die is rotating and cutter is cutting the finish material (pellet). Using Peddle conveyor, Pellet travels to Counter flow cooler. This cooler cools the pellet upto ambient temperature. The cooler is equipped with auto level sensor and grate mechanism for sufficient retention time (FIGURE-2). In Downstream, the pellet comes in vibrating screen wherein the fine particles are separated and pellets are stored in loose form as well as bagged and sealed with stretch wrapping machine.

**Figure 2: Pellexo Production plant**



#### 4. PRODUCT QUALITY ASSURANCE:

The quality assurance department daily monitors raw material and finish good quality parameters. Ash and moisture contents are critical and checked daily for every raw material arrives at plant. While presence of unwanted materials like plastics, threads, clothes peice, etc are inspected visually. Pellets are analyzed for its bulk density, moisture and mechanical durability. Periodically the pellets are also tested for calorific value, ash, chloride, sulfur, nitrogen content and fines generated at the end of production (James, 2005). Diameter and length of pellets are also physically measured as a part of quality assurance (Anna Wolf et al., 2006).(Table-1). The QA department is equipped with all required instrumentation like hot air oven, muffle furnace, analytical balances, bomb calorimeter and ligno tester for durability testing (Brigitte Hahn, 2004). The equipments are calibrated periodically for quality performance.

**Table 1: Specification of Pellexo pellets**

Sr.	Property	Unit of Measurement	Range
1	Diameter	mm	6 – 8
2	Length	mm	3 - 40
3	Moisture	As received, %	≤ 10
4	Net Calorific Value	As received, MJ/Kg	>16.0
5	Ash	% dry	< 1.0
6	Bulk Density	Kg/m <sup>3</sup>	≥ 650
7	Nitrogen	% dry	0.3
8	Sulfur	% dry	0.05
9	Chlorine	% dry	0.5
10	Arsenic	mg/kg dry	≤ 1
11	Cadmium	mg/kg dry	≤ 0.5
12	Chromium	mg/kg dry	≤ 10
13	Copper	mg/kg dry	≤ 10
14	Lead	mg/kg dry	≤ 10
15	Mercury	mg/kg dry	≤ 0.1
16	Nickel	mg/kg dry	≤ 10
17	Zinc	mg/kg dry	≤ 100
18	Ash melting behavior	degree C	>1200

#### 5. PRODUCT APPLICATIONS

Pellexo is used at the industrial, community and retail sectors (FIGURE-3). At industrial level, it is used for utility requirement for industrial units having FBC boilers, Traveling grate boilers, Thermic fluid heaters, hot air generators and for co-firing in large thermal power plants. The product is suitable for all types of combustion system without modification in combustion system. It significantly improves energy output and thereby efficiency of production. At community level, it can be used at community cooking stoves and large spaces such as malls, educational institutions, etc. At retail level, it is used at the pellet stoves in domestic / home heating and cooking applications.

**Figure 3: Pellexo Bioenergy Pellets**



## **6. PRODUCT BENEFITS**

### **6.1 Clean Development Mechanism (CDM) benefit**

Pellexo uses these agriculture residues in a more efficient and innovative manner, so as to harness the energy in biomass. Pellexo are manufactured in customized sizes, which make them suitable for various industries. Use of 10,000 tonnes per day of bio-pellets replaces 5600 tonnes per day of coal, reduces 3746400 tonnes of CO<sub>2</sub> per year generating revenue in terms of Clean Development Mechanism (CDM) benefit.

Coal, Lignite and other fossil fuels are replaced by Pellexo. One tonnes of Pellexo replaces 1.5 tonnes of lignite. We estimated that the client would successfully reduce 1.5 tons of CO<sub>2</sub>, as well as other local pollutants such as SO<sub>x</sub>, NO<sub>x</sub> and SPM by replacing 1 ton of coal with Pellexo, resulting in significantly improved workplace and surrounding environment.

CDM benefits to be availed to the clients, for which Abellon has an in-house team of CDM experts who help the clients understand the CDM mechanism, take appropriate actions to comply with the same, obtain CDM approval for their projects, and ultimately, gain the financial and environmental benefits accruing from the same in the form of Carbon Emission Reduction (CER). Preparation of case study based on successful replacement of fossil fuels and resulting environment and economic benefits to the clients (Milind et al., 2000). Pellexo also helps our clients to meet their Pollution Control Obligations, adds scope for earnings through CDM and assists them in branding their organizations as clean, green and environmentally responsible.

### **6.2 Environmental Benefit**

- Pellexo has a calorific value of 4100 kcal/kg. Energy produced would be approx. 4.7683 kilowatt hour (kW·h)/kg
- Coal and Lignite are replaced by Pellexo. One tone of Pellexo replaces 1.5 tonnes of lignite.
- 1 tonne of Coal with Pellexo can reduce 1.7 tonnes of CO<sub>2</sub>.
- Reducing deforestation, reducing local air, water or ground pollution, reducing indoor air pollution, or improving waste management.

**Table 2: Pellexo pellets and comparison of emission with conventional fuel.**

Fuel	GCV (Kcal/kg)	Displacement with pellexo (ton to ton)	CO2 Emission per ton of consumption	Ash (%)	Sulfur (%)	SOx (Kg/tonne)	Moisture (%)
Lignite	2500 - 3000	1.36-1.64	1.64	25-35	1 to 4	20 -80	20 -40
Indian coal	3500-3800	1.07 -1.17	1.52	20-30	0.5 -1	10/20/11	05/20/11
Important coal	5000-5500	0.75 – 0.82	1.53	10	0.5 - 0.7	10/15/11	05/15/11
Pellexo	4100	1	Carbon Neutral	<5	0.5	10	<10

### 6.3 Social and Economic Benefits

- Wealth-out-of-Waste (WoW): Approached 102 villages for collection of agri-residues to be supplied for Abellon's Biomass initiatives.
- Employment Generation from the entire initiative: About 15000 Income Generation Programs for farmers – Krushisabha: About 385 rounds of Krushisabhas organized till date Addressed about 14,000 - 15,000 farmers in 210 villages of Gujarat, India. 20% increase in annual income of farmers i.e. raise of US\$ 218 per person/annum
- Inclusive rural development initiatives: Education enhancement through providing knowledge for English and Computer in rural schools.

## 7. CONCLUSION

Pellexo is highly dense, compressed, low moist material which is primarily derived from compacted agricultural residue or waste wood. It has been proven to be effective bio fuel that can be utilized in many energy generation system. It is environmentally friendly and carbon neutral compare to other conventional fossil fuel. Pellexo is currently used at national and international level for domestic and industrial energy generation.

## 8. REFERENCES

- James, G. S., 2005, Handbook of Coal Analysis. Hoboken, NJ: John Wiley & Sons, Inc.
- Anna Wolfa, Anna Vidlundb, Eva Andersson, 2005, Energy-efficient pellet production in the forest industry—a study of obstacles and success factors, Biomass and Bioenergy, 30, pp 38–45.
- Milind Pathak, Leena Srivastava, Sudhir Sharma, 2000, India: CDM Opportunities and Benefits, available on <http://www.siam.gov.co>
- Brigitte Hahn, 2004, Existing Guidelines and Quality Assurance for Fuel Pellets, available at [www.umbra.at](http://www.umbra.at)

# Bamboo as Substitute of Wood for Sustainable Development

Neera Sarmah<sup>25</sup>

## Abstract

*To generate the employment for rural communities. To create awareness of environmental issues. To understand the benefits of taking care of Bamboo. To understand the holistic approach of Bamboo. To have continual improvement in Bamboo Related Activities. To attain a sustainable quality of life among the forest dwellers through local up-skilling and development of handicrafts.*

*Steps towards meeting objectives: identify various local skill potential and kinds of available raw material; fine tune the skill potential and raw material availability, skill enhancement procedures with market viability; devise product associated Capacity Building capsules & Action Plan; create market opportunities worth Rs. 6500 crore with an investment of Rs. 2600 crore, enabling 5 million families of artisans and farmers crossing the poverty line (AS PER NBM).*

*Skill Enhancement: Identify and short list Trainers-Facilitators in the fields of design possessing latest technological skills. Create Master Crafts Persons, with upgraded skill, awareness in technology, efficiently communicative and sound in various marketing strategies. Deliver further training to create good artisans. Exclusive selected few product should be produced by highly skilled artisans, resulting in uniformity of size and shape & easy mrkt. Continuous skill up gradation.*

*Innovative Designing. Bi-focal approach for product development. Emphasis on products for the masses -affordable. easily maintainable and sustainable design, Select skilled artisans for specialization to produce quality product with an eye on the International Market. Introduction of new designs. Use new technologies and Grow into something else, rather than keeping on repeating the same design, because it was successful earlier. Continuous adaptation of new global designs.*

*Uniqueness of Bamboo. Bamboo sprouted again after the Nuclear Bomb blast in Japan. Can grow on de-graded soil. In Columbia & Equador Bamboo are used for fishing. In Europe Bamboo is used for the production of Rayon. Bamboo houses can sustain in the earthquakes of 7.6 richter scale. In China for the Construction of Bridges the Bamboos are used today also. Bamboo shoots are rich in Thiamine, Vit B, Potassium, Cellulose & aminoacid, 17 enzymes & also minerals like selenium. Italian Government is planning to purchase the Bamboos from India, Tanzania & Equador. Few Bamboo varieties can reach the height of 60 mtr or more. Substitute for tobacco plantation. Bamboo serves as the best wind-break. Most assured profitable crop for the farmers. Bamboo for our Earth. Wind Break. Absorbs maximum green house gases. Helps to reduce the temperature by 3 to 4 degree celsius. Halts soil erosion & land slides. It is a self manuring plant. Produces maximum quantity of Biomass. Can have Inter cropping or mixed cropping successfully. Benefits of Bamboo Power. Environment and Eco Friendly. Avenue generation activities for equal distribution of economy. Employment availability in rural areas. Resource Utility, profitable farm activity. Replacement of wood to save our forest and wild-life. Healthy socio-economic life. Bamboo Power Implementation Benefits in Mountain Tourism. A step towards controlling Global Warming. Balanced forest/nature. Easily re-cyclable. Healthy utility for human being. Employment opportunities. Self reliance. Reversal of ecological degradation of bio-diversity.*

---

<sup>25</sup> India (neecol@rediffmail.com)

*Scope: Handicraft development safest tool for eco-sustainability of the forest communities. It has potential for strengthening Local livelihood- poverty alleviation. Design creation and careful mrkt survey sine-qua-non for any success. Create industry sponsored plantations of all such imp species.*